



# BF03S

SHALLOW WELL JET PUMP

## Residential Water Systems

### FEATURES

**Self-Adjusting Capacity:** Automatically adjusts to the water demand within the pump's capacity.

**Compact:** Can be easily installed in locations where other larger pumps are difficult to install.

**Tankless:** Self-contained water system, no separate tank required.

**Exclusive Air Handling Ability:** When pump is primed it never needs priming again even if the water level drops below the end of the suction pipe. It resumes pumping as soon as the water level rises again. Gas or air in the water will not air-bind the pump.

**Protected Mechanical Seal:** Water is retained in the casing so the seal can never run dry.

**Easy to Service:** Pump has nozzle clean-out plug. Provides easy access to nozzle and diffuser for cleaning. Back pull-out design - pipes do not have to be disturbed.

**Powered for Continuous Operation:** Pump ratings are within the motor's working limits, can be operated continuously without damage.

**Corrosion Resistant:** Electro-coat paint is applied inside and out, then baked on.

### DIMENSIONS AND WEIGHTS

(All dimensions in inches and weight in lbs.)  
(Do not use for construction purposes.)

| HP/Model | ① ½ HP - BF03S |
|----------|----------------|
| Weight   | 69             |
| Length   | 20             |
| Width    | 10½            |
| Height   | 15             |

### APPLICATIONS

Specifically designed for:

- Small homes
- Camps
- Mobile homes

### PUMP SPECIFICATIONS

- Pipe connections:  
¾" suction,  
¾" discharge
- Pressure switch: AS3 (20-40)

### MOTOR SPECIFICATIONS

- NEMA standard
- 115/230V, 60 Hz
- Single phase
- 3500 RPM
- Built-in overload with automatic reset.
- Capacitor start type
- Stainless steel shaft
- ½ HP - see page 3 ①

### SYSTEM COMPONENTS

- Basic Pump Unit: Includes pump, motor, pressure switch, tubing and fittings, air volume control valve, suction check valve, nozzle and diffuser.

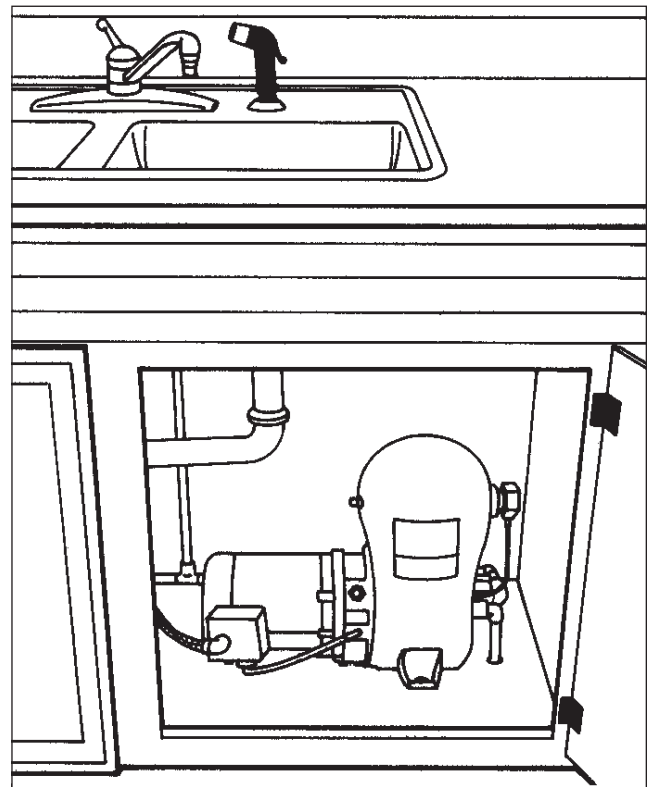

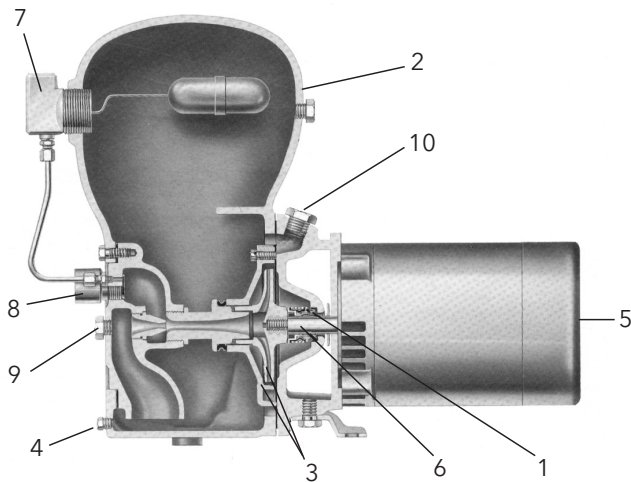

### COMPONENTS

1. Mechanical Seal
2. Casing
3. Impeller and Guide Vane
4. Drain Plug
5. Two-Compartment Motor
6. Stainless Steel Shaft
7. Air Volume Control
8. Check Valve
9. Nozzle Clean-Out Plug
10. Priming Plug

*Repair parts may be found in RJETPARTS book.*

### PERFORMANCE RATINGS

| HP/Model                     | ① ½ HP - BF03S           |           |                              |
|------------------------------|--------------------------|-----------|------------------------------|
| Shallow Well Package         | None Required            |           |                              |
| Adapter                      | Built-In                 |           |                              |
| Nozzle                       | AN015                    |           |                              |
| Venturi (Diffuser)           | 4K5                      |           |                              |
| Total Suction Lift<br>(Feet) | Discharge Pressure (PSI) |           | Maximum<br>Shut-Off<br>(PSI) |
|                              | 20                       | 30        |                              |
|                              | Gallons Per Hour / GPM   |           |                              |
| 5                            | 525 / 8.8                | 380 / 6.3 | 51                           |
| 10                           | 480 / 8.0                | 330 / 5.5 | 49                           |
| 15                           | 410 / 6.8                | 290 / 4.8 | 46                           |
| 20                           | 350 / 5.8                | 255 / 4.3 | 44                           |
| 25                           | 265 / 4.4                | 220 / 3.7 | 42                           |

① Pump now uses a ½ HP motor due to ⅓ HP motors being obsolete.

# Xylem |'zīləm|

- 1) The tissue in plants that brings water upward from the roots;
- 2) a leading global water technology company.

We're 12,500 people unified in a common purpose: creating innovative solutions to meet our world's water needs. Developing new technologies that will improve the way water is used, conserved, and re-used in the future is central to our work. We move, treat, analyze, and return water to the environment, and we help people use water efficiently, in their homes, buildings, factories and farms. In more than 150 countries, we have strong, long-standing relationships with customers who know us for our powerful combination of leading product brands and applications expertise, backed by a legacy of innovation.

**For more information on how Xylem can help you, go to [www.xylem.com](http://www.xylem.com)**



Xylem, Inc.  
2881 East Bayard Street Ext., Suite A  
Seneca Falls, NY 13148  
Phone: (866) 325-4210  
Fax: (888) 322-5877  
[www.xylem.com/brands/gouldswatertechnology](http://www.xylem.com/brands/gouldswatertechnology)

Goulds is a registered trademark of Goulds Pumps, Inc. and is used under license.  
© 2012 Xylem Inc. BBF03S August 2011