

SQ, SQE, SQE-NE

Submersible pumps and accessories
50/60 Hz



1. Product Introduction	4
Applications	4
Features and Benefits	4
Performance range	5
Pump and motor range	7
Pipe connection	7
Type key	7
Pumped liquids	7
2. Features and benefits	8
Dry-running protection	8
High pump efficiency	8
High motor efficiency	8
Wear resistance	8
Protection against upthrust	8
Excellent starting capabilities	8
Overvoltage and undervoltage protection	9
Overload protection	9
Overtemperature protection	9
Reliability	9
Variable speed	9
Installation	9
Service	9
Factory settings	10
3. Application examples	11
SQ with pressure switch and pressure tank	11
SQ with Pressure Manager (with or without pressure tank)	12
Constant-pressure control with CU 301, residential water supply	13
Constant-pressure control with the CU 301, irrigation	14
Maintaining a constant water table	15
Emptying or filling a tank	16
Pumping from one tank to another	17
Workshop setting of operating parameters	18
Manual speed control of SQE (sampling)	19
Replacement in existing installation	20
4. Control units	21
CU 301 constant pressure control	21
CU 300 multi-function control	23
Benefits of CU 300 and Grundfos GO Remote	24
5. Pump selection	25
Determining head and flow	25
Pump sizing	26
Selection of pressure tank	27
Variable speed	28
Selecting the right pump for the SQE constant-pressure system	29
Curve conditions	30
6. Performance curves and technical data	31
SQ 1, SQ 1-N, SQE 1, SQE 1-N	31
SQ 2, SQ 2-N, SQE 2, SQE 2-N	33
SQ 3, SQ 3-N, SQE 3, SQE 3-N	35
SQ 5, SQ 5-N, SQE 5, SQE 5-N	37
SQ 7, SQ 7-N, SQE 7, SQE 7-N	39
SQE 2-NE	41
Dimensions and weights	42
SQE 5-NE	43
Dimensions and weights	44
7. Technical data	45
SQ and SQE pumps	45
CU 300 and CU 301 control units	45
Material specification, pump	46

Material specification, motor	46
Material specification, pump	47
Material specification, motor	47
8. Resistance list, SQE-NE	48
Wiring diagrams	53
Electrical connection of CU 301	53
Electrical connection of CU 300	54
9. Accessories	55
CU 301	55
Pressure sensor for CU 301	55
Constant-pressure package without the pump	55
Constant-pressure packages with the pump	55
CU 300	55
Grundfos GO Remote MI 301	55
SPP 1 potentiometer	55
Pressure Manager	56
Pressure gauge	56
Pressure tank	56
Submersible drop cable	56
Cable termination kit, type KM	57
Cable clips	57
Straining wire	57
Wire clamp	57
Zinc anodes	58
Flow sleeve	58
10. Order data	59
SQ, SQ-N, SQE, SQE-N	59
Complete unit, 1 × 200-240 V, 1.5 m cable	59
SQE-NE	60
Complete unit, 1 × 200-240 V	60
Submersible drop cables	61
SQ and SQE including cable	62
11. Grundfos Product Center	63

1. Product Introduction

SQ pumps are submersible pumps available in the following versions:

- SQ
- SQ-N
- SQE
- SQE-N
- SQE-NE.

Applications

SQ and SQE pumps are suitable for both continuous and intermittent operation for a variety of applications:

- domestic water supply
- small waterworks
- irrigation
- tank applications
- pressure boosting.

SQE-NE pumps are suitable for environmental applications, such as remedial pumping or sampling at:

- refuse dumps
- chemical sites
- industrial sites
- garages and petrol stations.

Note: For other applications, please contact Grundfos.

Features and Benefits

SQ pumps offer the following features:

- dry-running protection
- high pump and motor efficiency
- wear resistance
- protection against upthrust
- soft starter
- overvoltage and undervoltage protection
- overload protection
- overtemperature protection.

Additionally, SQE pumps offer the following benefits:

- variable speed
- electronic control and communication.

The motors are based on the most recent technology within permanent magnets. This technology is the main reason for the high efficiency of the motors. The motors have a built-in electronic unit containing a frequency converter featuring soft start.

SQ pumps are fitted with a single-phase Grundfos MS 3 or MS 3-NE motor, and by means of the built-in frequency converter, the motor is driven at a constant speed.

SQE pumps are also fitted with a single-phase Grundfos MSE 3 or MSE 3-NE motor. Both motor types can communicate with the Grundfos CU 300 and CU 301 control units, which can be operated with Grundfos GO Remote.

SQE pumps feature variable speed which is offered through frequency control. This means that the pump can be set to operate in any duty point in the range between the pump minimum and maximum performance curves.

CU 301 is specially developed for applications where a constant pressure is required.

CU 300 and CU 301 provide full control of SQE pumps. In case of pump fault, the front of the CU 300 or CU 301 shows an alarm. Grundfos GO Remote enables monitoring of the installation and changing of the factory settings.

SQE pumps can operate without a CU 300 or CU 301. However, in such case, the pump does not offer all the features available when connected to a CU 300 or a CU 301.

Performance range

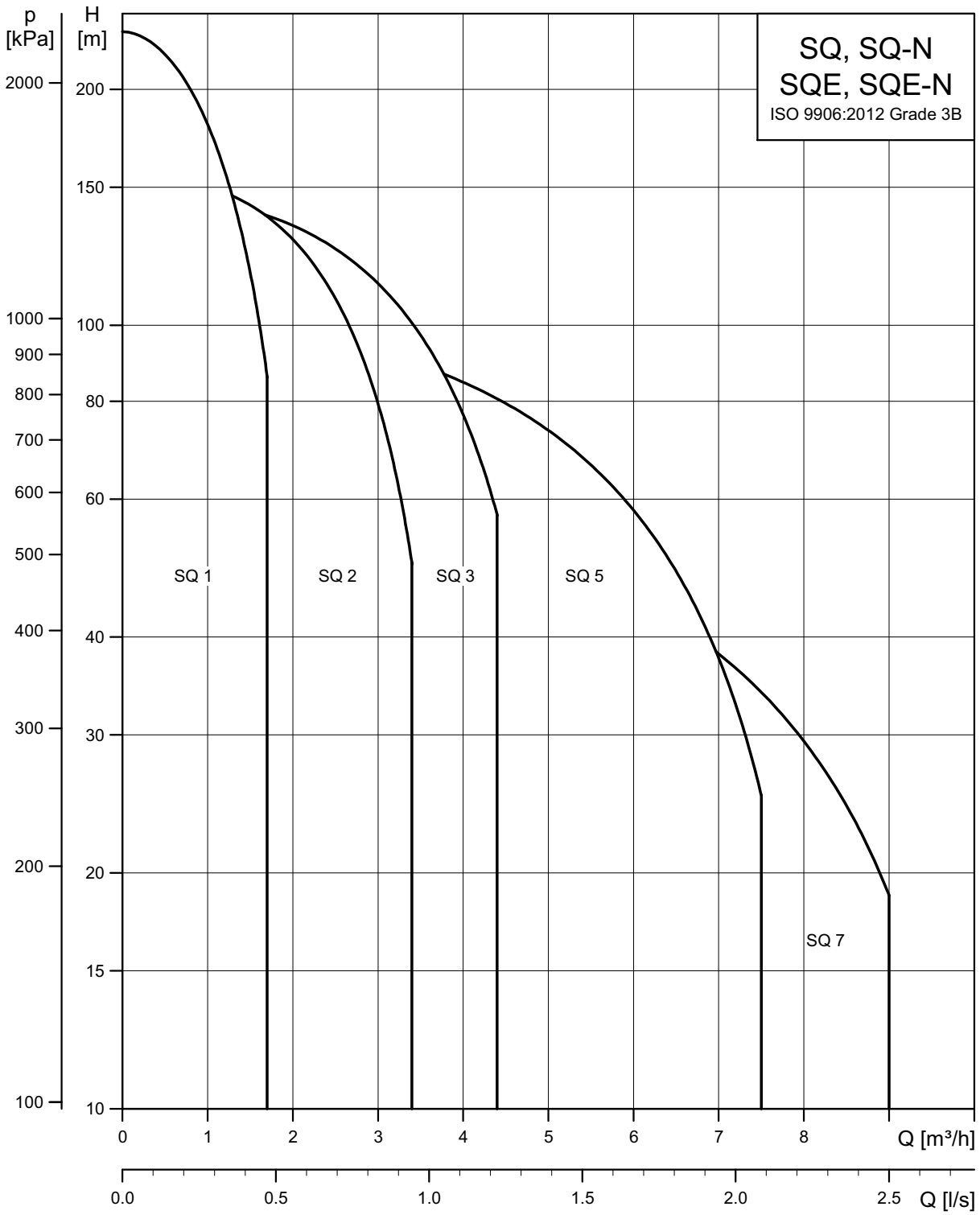

TM02 9976 4620

Fig. 1 Performance range, SQ/SQ-N/SQE/SQE-N

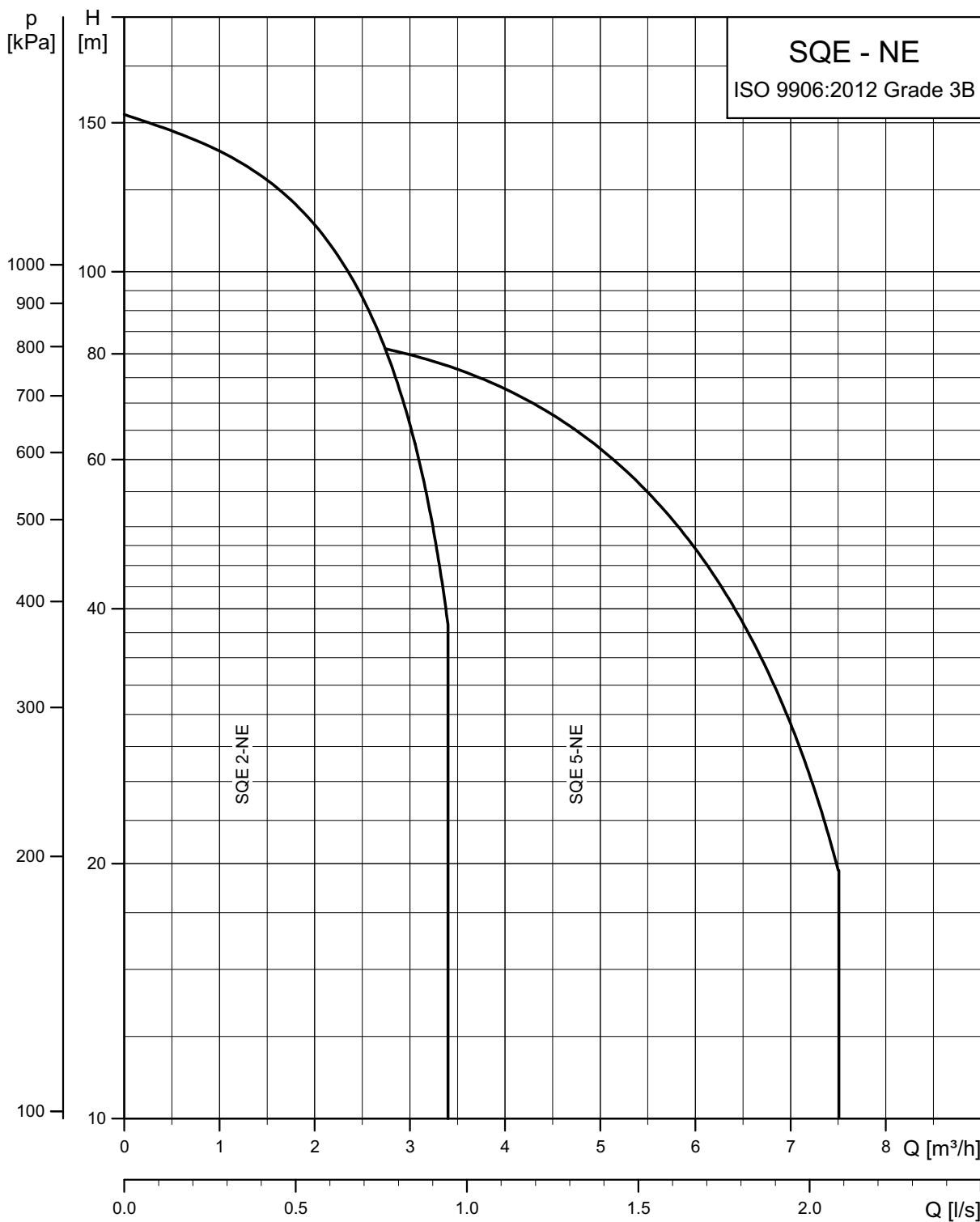

TM01 9343 4220

Fig. 2 Performance range, SQE-NE

Pump and motor range

Product	Description	Material
SQ, SQE pump	(1, 2, 3, 5, and 7 m ³ /h)	Stainless steel EN 1.4301, AISI 304
SQ-N, SQE-N pump	(1, 2, 3, 5, and 7 m ³ /h)	Stainless steel EN 1.4401, AISI 316
SQE-NE pump	(2 and 5 m ³ /h)	Stainless steel EN 1.4401, AISI 316
MS 3 motor	Single-phase Max. 1.85 kW	Stainless steel EN 1.4301, AISI 304
MS 3-NE motor	Single-phase Max. 1.85 kW	Stainless steel EN 1.4401, AISI 316
MSE 3 motor	Single-phase Max. 1.85 kW	Stainless steel EN 1.4301, AISI 304
MSE 3-NE motor	Single-phase Max. 1.85 kW	Stainless steel EN 1.4401, AISI 316

Pipe connection

Pump type	Threaded connection
SQ 1, SQ 2, SQ 3	Rp 1 1/4
SQ 5, SQ 7	Rp 1 1/2

Type key

Code	Example	SQ	E	2	-55
	Type range				
	Basic version				
E	Electronic control and communication				
	Rated flow rate [m ³ /h]				
	Head [m] at rated flow rate				
	Material code: Stainless steel EN 1.4301				
N	Stainless steel EN 1.4401				

Pumped liquids

The SQ and SQE pumps are suitable for pumping thin, clean, non-aggressive, non-explosive liquids, not containing solid or long-fibred particles larger than sand grains. The pH value of the pumped liquid should be between 5 and 9.

The SQE-NE pumps are applicable in contaminated or hydrogen-carbonate-containing groundwater. The pH value should be between 2 and 13.

For further information, see section 8. [Resistance list, SQE-NE](#).

Sand content

The maximum sand content allowed is 50 g/m³. A higher sand content will reduce pump life due to wear.

Temperature

Due to differences in regulations, temperature limits have been determined according to the following regions:

- West European
- Central European
- Asian-Pacific
- North American.

For the West European, Central European and Asian-Pacific region, the following table applies:

Flow velocity past the motor	Max. liquid temperature [°C (°F)]
0 m/s (free convection)	35 (95)
Min. 0.15 m/s	40 (105)

Temperature limit on the motor nameplate: 35 °C.

Note: UL accepts only one temperature limit to be stamped on the motor nameplate. Identical motors are used in the following regions:

- West European
- Central European
- Asian-Pacific
- North America.

For the North American region, the following table applies:

Flow velocity past the motor	Max. liquid temperature [°C (°F)]
0 m/s (free convection)	30 (86)

Note: According to UL regulations, the temperature of the pumped liquid must not exceed 86 °F (30 °C) for products in the North American region.

Viscosity

The pumping of liquids with a viscosity higher than that of water will cause the following:

- head loss
- higher power consumption.

If in doubt, contact Grundfos.

2. Features and benefits

Dry-running protection

The pumps are protected against dry running. A value of $P_{\text{cut-out}}$ ensures cut-out of the pump in case of water shortage in the borehole, thus preventing a burnout of the motor.

The dry-running protection is active after 30 seconds of operation. The dry-running alarm is activated when the load has been below the minimum power limit for an accumulated time of 5 seconds.

$P_{\text{cut-out}}$ is factory-set both for the SQ and SQE pumps. On SQE, the dry-run limit can be adjusted with Grundfos GO.

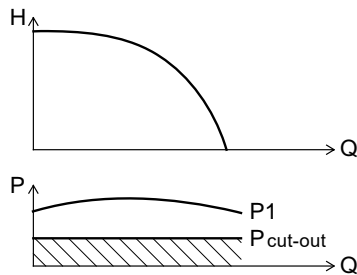

Fig. 3 Dry-running protection

TM01 2751 2298

High pump efficiency

The hydraulic pump components are polyamide-reinforced with 30 % glass fibre. The hydraulic design ensures high pump efficiency, yielding low energy consumption and thus low energy costs.

High motor efficiency

The motors are designed according to the permanent-magnet principle (PM motor), featuring high efficiency within a wide performance range.

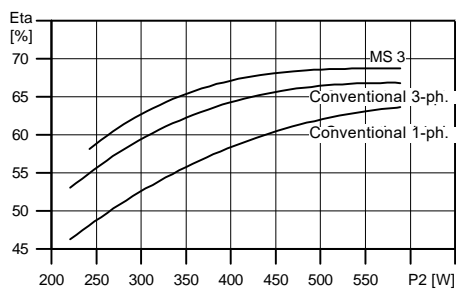

Fig. 4 Comparison of motor efficiency

TM01 2698 2298

Wear resistance

The pump impellers are not fastened to the shaft ("floating"). Each impeller has its own tungsten carbide/ceramic bearing. The design and the materials chosen ensure high wear resistance to sand, thus long product life.



Fig. 5 Impellers

TM01 3141 3498

Protection against upthrust

Starting up a pump with a very low counter pressure involves the risk of the entire impeller stack being lifted. This phenomenon is called upthrust. Upthrust may cause breakdown of both pump and motor.

The motors are fitted with an upthrust bearing protecting both pump and motor against upthrust, thus preventing breakdown during the critical start up phase.

Excellent starting capabilities

The integrated electronic unit of the motor includes soft starting. Soft starting reduces the starting current, thus gives the pump a smooth and steady acceleration.

The soft starter minimises the risk of wear of the pump and prevents overloading of the mains during start up.

The excellent starting capabilities are a result of the high locked-rotor torque of the permanent-magnet motor, and the few pump stages. High starting reliability also applies in case of low voltage supply.

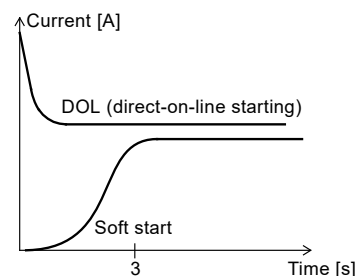

Fig. 6 Comparison of locked-rotor current

TM01 3479 4198

Overvoltage and undervoltage protection

Overvoltage and undervoltage may occur in case of unstable voltage supply.

The integrated protection of all motors prevents damage to the motor in case the voltage moves outside the permissible voltage range.

The pump is cut out if the voltage falls below 150 V or rises above 315 V. The motor automatically restarts when the voltage returns within the permissible range. Consequently, no extra protection relay is required.

Overload protection

If the pump is exposed to heavy load, the current consumption rises. The motor automatically compensates for this by reducing the speed. If the speed falls below 3000 min^{-1} , the motor is cut out.

If the rotor is prevented from rotating, it is automatically detected and the power supply is cut out. Consequently, no extra motor protection is required.

Overtemperature protection

A permanent-magnet motor gives off very little heat to its surroundings. In combination with an efficient internal circulation system leading the heat away from the rotor, stator and bearings, optimum operating conditions are ensured for the motor.

As an extra protection, the electronic unit has a built-in temperature sensor. When the temperature exceeds a critical limit, the motor is cut out. When the temperature returns below the limit, the motor is automatically cut in again.

Reliability

The motors have been designed with high reliability and have the following features:

- tungsten carbide or ceramic bearings
- thrust bearings protecting against downthrust
- product life equal to conventional AC motors.

Variable speed

The MSE 3 motor enables variable speed control within the range of $3,000$ to $10,700 \text{ min}^{-1}$. The pump can be set to operate in any duty point within the $3,000$ to $10,700 \text{ min}^{-1}$ performance range of the pump. Consequently, the pump performance can be adapted to any specific requirement.

The variable-speed control facility requires the use of a CU 300 or CU 301 control unit and Grundfos GO Remote. See page 28.

Installation

SQ and SQE may be installed vertically, horizontally or in any position in between.

Note: The pump must not fall below the horizontal level in relation to the motor.

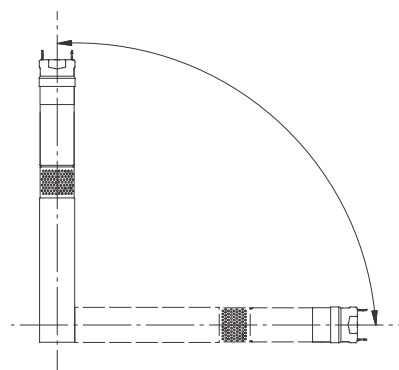

Fig. 7 Installation of SQ/SQE pumps

The following features ensure simple installation of the pump:

- built-in non-return valve with spring
- low weight facilitating handling
- installation in 3-inch or larger boreholes
- on/off switch without extra motor starter or starter box necessary
- SQE available with cable with a motor plug (up to 100 m).

For horizontal installation, we recommend that you install the pump in a flow sleeve, for the following reasons:

- to ensure sufficient flow velocity past the motor, thus provide sufficient cooling
- to prevent motor and electronic unit from being buried in sand or mud.

Service

The modular pump and motor design facilitates installation and service. The cable and plug are fitted to the pump with screws, which enables replacement.

Factory settings

Alarm	200-240 V motors				100-115 V motors
	0.7 kW	1.15 kW	1.55 kW	1.85 kW	0.7 kW
Overvoltage ¹	280 VAC	280 VAC	280 VAC	280 VAC	150 VAC
Undervoltage	Speed reduction: 198 V	Speed reduction: 198 V	Speed reduction: 207 V	Speed reduction: 207 V	Speed reduction: 90 V
	Stop limit: 150 V	Stop limit: 150 V	Stop limit: 150 V	Stop limit: 150 V	Stop limit: 75 V
Dry-running stop	300 W 550 W ²	680 W	800 W	900 W	300 W
Speed reduction	In connection with undervoltage or overload				
Electronics temperature	Stop limit: 60 °C	Stop limit: 65 °C	Stop limit: 65 °C	Stop limit: 70 °C	Stop limit: 70 °C
	Restart: 50 °C	Restart: 55 °C	Restart: 55 °C	Restart: 60 °C	Restart: 60 °C
Overload	5.2 A	8.4 A	11 A	12 A	12 A

- 1 200-240 V motors: Operation is guaranteed up to 280 VAC.
 100-115 V motors: Operation is guaranteed up to 150 VAC.
 In order to avoid unnecessary stops, the overvoltage stop limit is as stated.

- 2 Applies only to SQ/SQE 2-55.

3. Application examples

SQ with pressure switch and pressure tank

SQ is ideally suited for domestic water supply in single-family dwellings, or summer cottages not connected to municipal waterworks. SQ is easy to install and operate

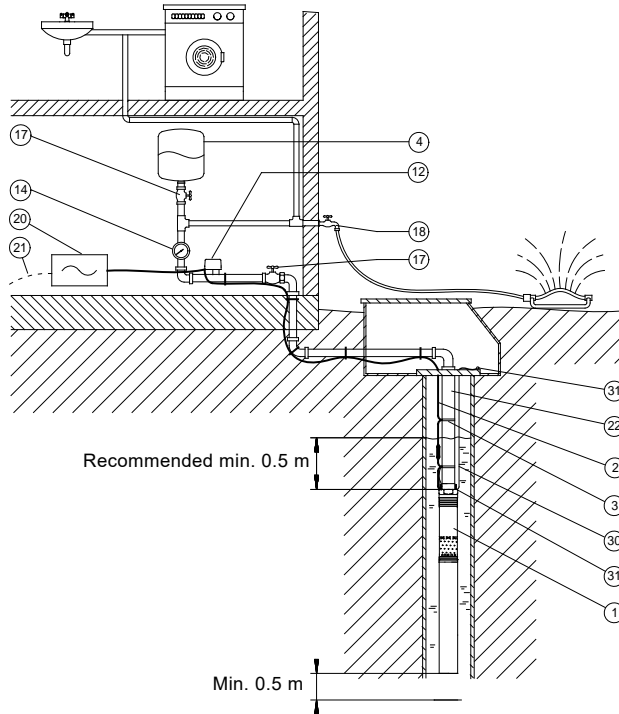

- 1 SQ pump
- 2 Cable
- 3 Cable clips
- 4 Pressure tank¹
- 12 Pressure switch
- 14 Pressure gauge
- 17 Isolating valve
- 18 Tap
- 20 Mains switch
- 21 Mains connection, 1 × 200-240 V, 50/60 Hz
- 22 Riser pipe
- 30 Straining wire
- 31 Wire clamp

¹ For selection of pressure tank, see page 59.

Fig. 8 Domestic water supply

TM01 2447 1798

SQ with Pressure Manager (with or without pressure tank)

Features and benefits

If water is consumed, the pump is cut in via the Pressure Manager. The pressure tank is installed between the pump and the Pressure Manager. In an installation with a pressure tank, water is supplied as soon as a tap is opened. This means that the pressure tank takes over water supply during the smooth start up of the pump (about 3 seconds).

When the water consumption stops (flow is zero), the pump continues operating for 10 seconds, building up pressure in the pressure tank.

The setting of the tank precharge pressure depends on the water level (difference of height between water level and Pressure Manager).

The setting of the flow-pipe pressure at the pressure tank depends on the water level (difference of height between water level and Pressure Manager) according to the following table:

Difference of height [m]	Flow-pipe pressure in pressure tank [bar]
0	1.22
10	1.0
20	0.77
30	0.56

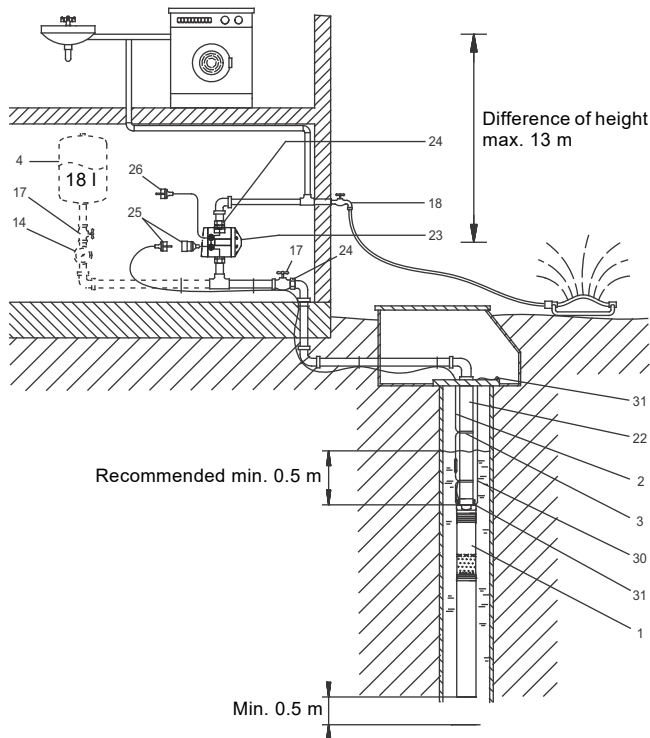

- 1 SQ pump
- 2 Cable
- 3 Cable clips
- 4 Pressure tank
- 14 Pressure gauge
- 17 Isolating valve
- 18 Tap
- 22 Riser pipe
- 23 PM 1 or PM 2 Pressure Manager available with/without plug
- 24 Union
- 25 Plug
- 26 Mains connection, 1 × 200-240 V, 50/60 Hz, for PM 1 or PM 2
- 30 Straining wire
- 31 Wire clamp

Note: For the Pressure Manager, back-up fuse should not exceed 10 A.)

System pressure: max. 10 bar.

The following pump types can be used:

SQ 1-65, SQ 1-80, SQ 2-35, SQ 2-55, SQ 2-70, SQ 2-85, SQ 3-40, SQ 3-55, SQ 3-65, SQ 3-80.

The installation must be designed for maximum pump pressure.

Do not install draw-off points between the pump and the Pressure Manager.

Fig. 9 SQ with Pressure Manager

Constant-pressure control with CU 301, residential water supply

Features and benefits

The system maintains a constant pressure within the maximum pump performance in spite of a varying water consumption.

The pressure is registered by the pressure sensor and transmitted to CU 301. CU 301 adjusts the pump performance accordingly.

Function

When a tap is opened, the pressure in the 8-litre tank will start to drop.

At a flow lower than approximately $0.18 \text{ m}^3/\text{h}$, the pressure will drop slowly. When the pressure in the tank is 0.5 bar below setpoint, the pump will start. The pump will run until the pressure is 0.5 bar above setpoint. This way of operation is called on/off operation.

At a flow higher than approximately $0.18 \text{ m}^3/\text{h}$, the pressure will drop quickly and the pump will start immediately and maintain a constant pressure.

During operation, CU 301 will control the pump speed to maintain a constant pressure. If there is no consumption, the pump will fill up the tank and stop after a few seconds.

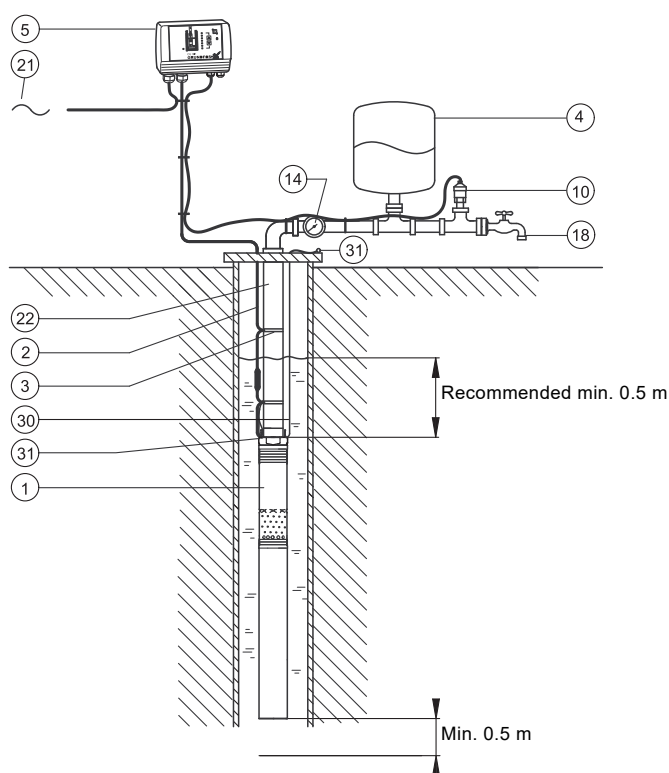

- 1 SQE pump
- 2 Cable
- 3 Cable clips
- 4 Pressure tank, 8 litres
- 5 CU 301 control unit
- 10 Pressure sensor, 0-6 bar
- 14 Pressure gauge
- 18 Tap
- 21 Mains connection, $1 \times 200\text{-}240 \text{ V}$, 50/60 Hz
- 22 Riser pipe
- 30 Straining wire
- 31 Wire clamp

If a higher constant pressure (max. 10 bar) is required, use a CU 300, pressure sensor and flow switch. See page 15.

Fig. 10 Residential water supply with the CU 301

TM03 3429 0406

Constant-pressure control with the CU 301, irrigation

Features and benefits

The system maintains a constant pressure within the maximum pump performance even in case of varying water consumption.

The pressure is registered by the pressure sensor and transmitted to CU 301. CU 301 adjusts the pump performance accordingly.

Function

When the sprinkler system is on, the pressure in the 8-litre tank starts to drop.

At a flow lower than approximately $0.18 \text{ m}^3/\text{h}$, the pressure drops slowly. When the pressure in the tank is 0.5 bar below setpoint, the pump starts. The pump runs until the pressure is 0.5 bar above setpoint. This way of operation is called on/off operation.

At a flow higher than approximately $0.18 \text{ m}^3/\text{h}$, the pressure drops quickly, and the pump starts immediately and maintains a constant pressure.

During operation, CU 301 controls the pump speed to maintain a constant pressure. If there is no consumption, the pump fills up the tank and stop after a few seconds.

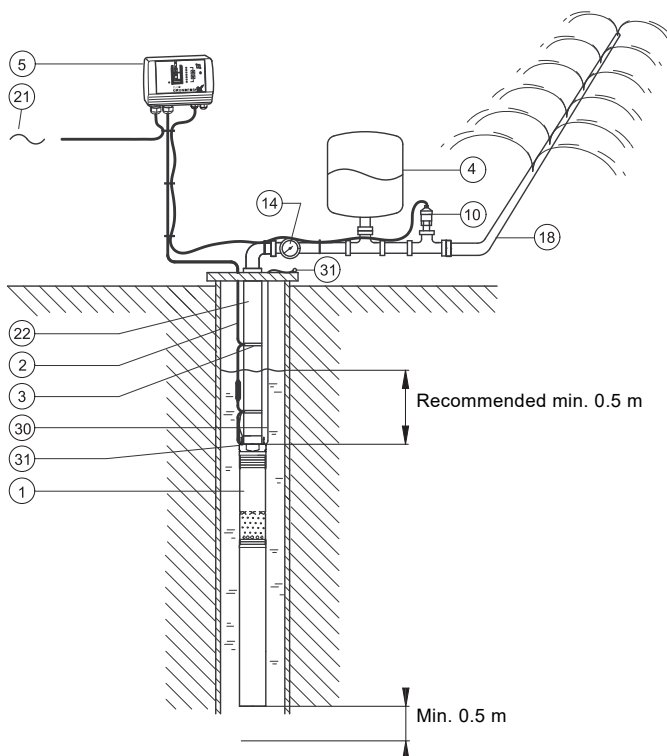

- 1 SQE pump
- 2 Cable
- 3 Cable clips
- 4 Pressure tank, 8 litres
- 5 CU 301 control unit
- 10 Pressure sensor, 0-6 bar
- 14 Pressure gauge
- 18 Sprinkler system
- 21 Mains connection, 1 × 200-240 V, 50/60 Hz
- 22 Riser pipe
- 30 Straining wire
- 31 Wire clamp

If a higher constant pressure (max. 10 bar) is required, use a CU 300, pressure sensor and flow switch. See page 15.

Fig. 11 Irrigation

Maintaining a constant water table

Features and benefits

A constant water table can be maintained by adjusting the pump performance. Maintaining a constant water table is important, for example, in connection with keeping out the groundwater of a building site, or preventing the penetration of salt water into a borehole containing potable water.

The example shows how to maintain a constant water table by adjusting pump performance.

Sensors

Level	Description	Reaction
Level sensor (11)		
Warning (max.)	Too high water level. Possible cause: insufficient pump capacity.	Alarm relay operates.
Desired level	The water level that must be maintained.	
Warning (min.)	Too low water level. Possible cause: too high pump capacity.	Alarm relay operates.

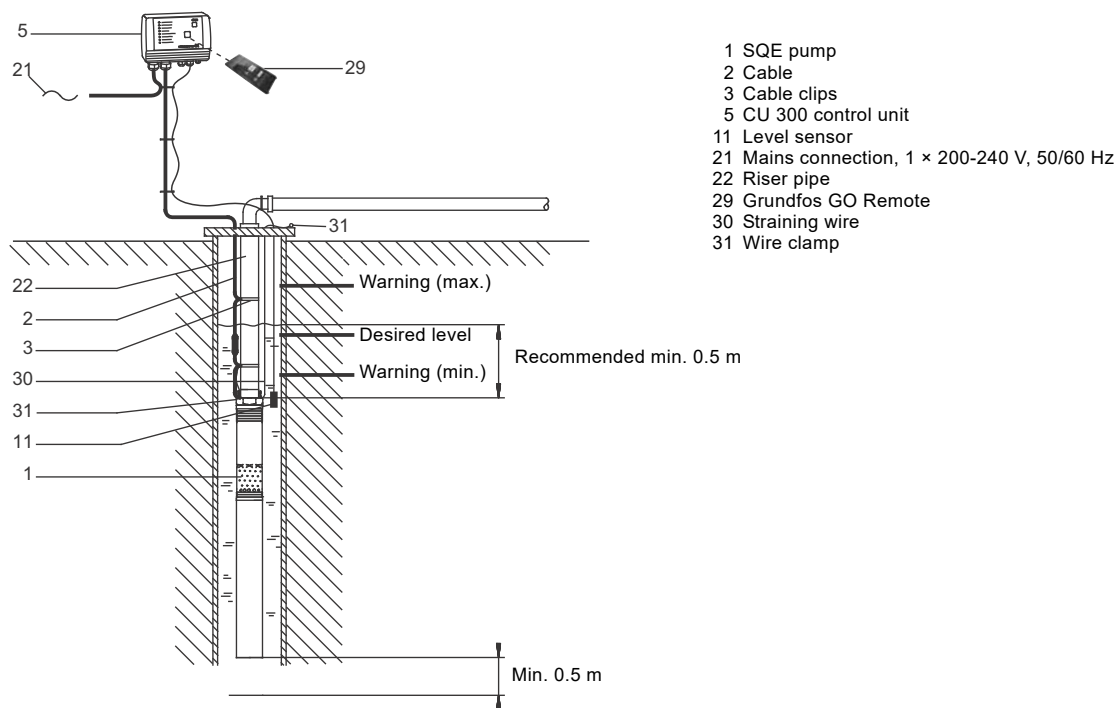

Fig. 12 Maintaining a constant water table

TM06 2196 3814

Emptying or filling a tank

SQE with a CU 300 is ideal for emptying or filling a tank.

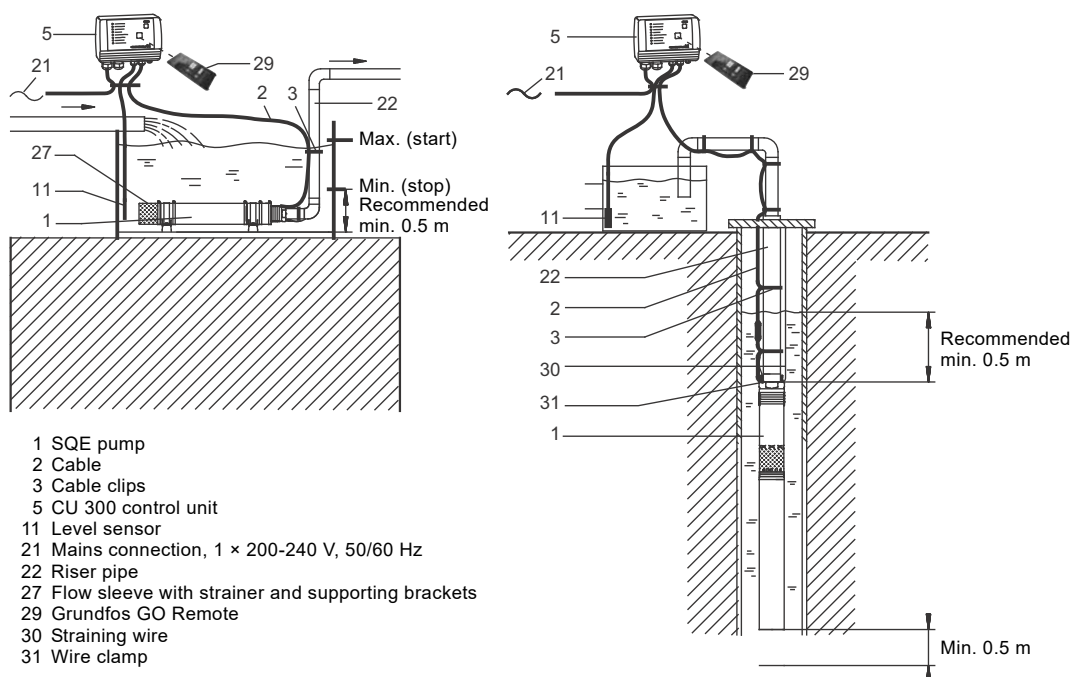

Fig. 13 Emptying or filling a tank

TM06 2198 3814

Pumping from one tank to another

Functioning and benefits

SQE is ideal for pumping water from one tank to another.

Sensors

Level	Description	Light indication on CU 300
Level sensor (11, tank at top)		
Max. (stop)	When the water reaches this level, the pump stops.	Green indicator light in ON/OFF button is flashing.
Min. (start)	When the water drops to this level, the pump starts.	Green indicator light in ON/OFF button is permanently on.
Level sensor (11, tank at bottom)		
Max. (start)	When the water reaches this level, the pump starts.	Green indicator light in ON/OFF button is on.
Min. (stop)	When the water drops to this level, the pump stops.	Green indicator light in ON/OFF button is flashing.

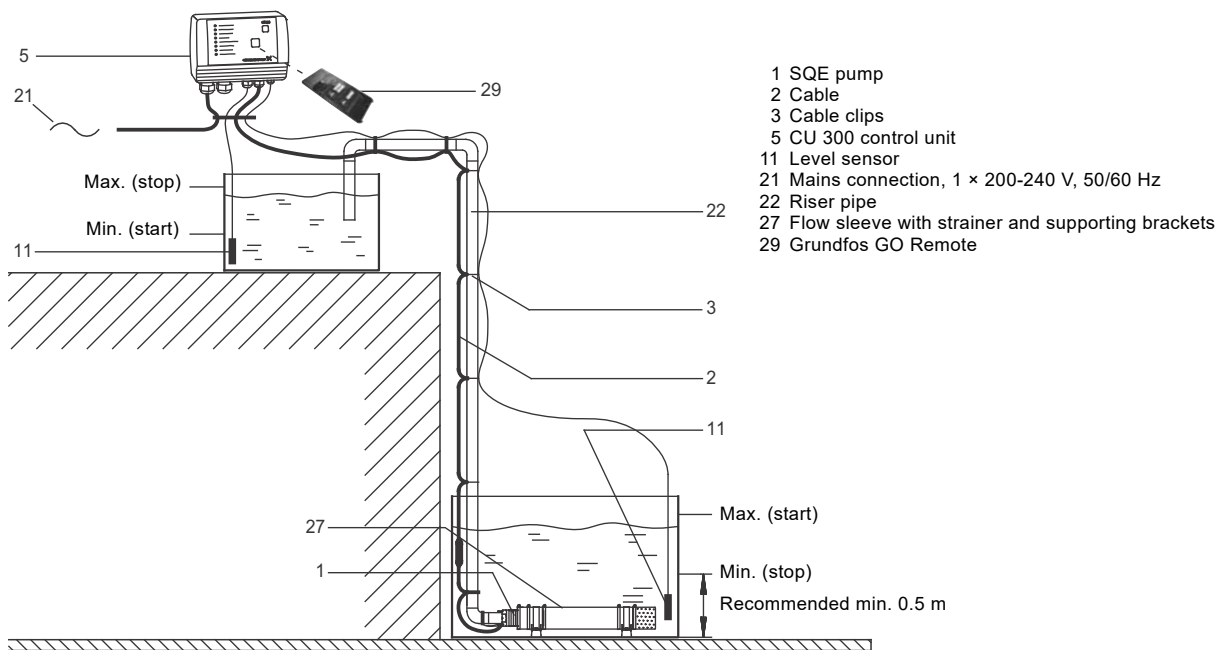

Fig. 14 Pumping from one tank to another

TM06 2195 3814

Workshop setting of operating parameters

Using CU 300 and Grundfos GO Remote enables changing the motor speed in a workshop, and thereby setting of the pump to a specific performance.

An SQE Speed Calculation program has been developed for the calculation of the speed to obtain the required flow rate and head.

Dry-running protection

The $p_{\text{cut-out}}$ value is factory set for SQE and it ensures dry-running protection.

If the speed of the pump is reduced by more than 1000 min^{-1} , the $p_{\text{cut-out}}$ value must be readjusted via CU 300 or CU301 and Grundfos GO Remote.

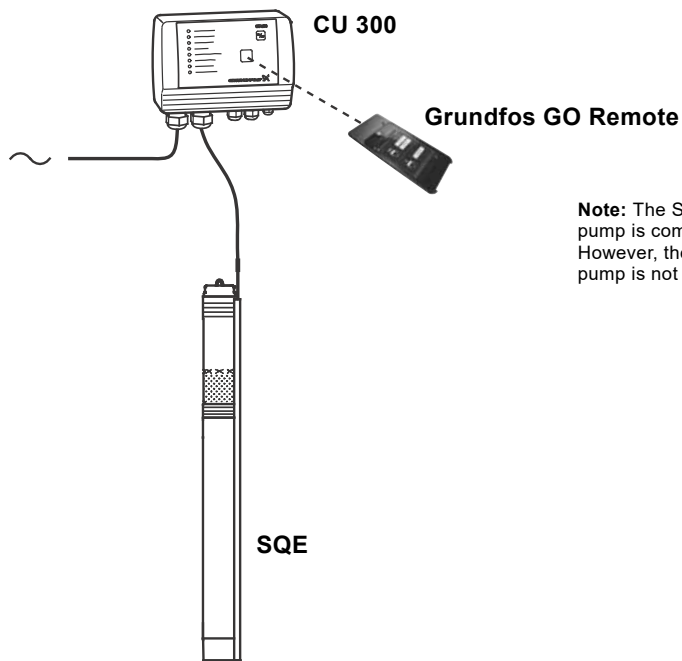

Note: The SQE pump must not be started until the pump is completely submerged below the water table. However, the motor speed can be changed even if the pump is not submerged.

Fig. 15 Setting of operating parameters

Manual speed control of SQE (sampling)

Features and benefits

Manual speed control of SQE is possible with an SPP 1 potentiometer and Grundfos GO Remote.

This application is especially suitable for sampling from groundwater monitoring wells. The monitoring well is purged at high speed and the sample is taken at a low speed (quiet flow). For contaminated groundwater, we recommend the SQE-NE pump range.

If frequent sampling is required, we recommend dedicated installation of the pump, thus eliminating wear and additional costs caused by frequent assembly and dismantling of the installation.

Important: Through dedicated installation, the transfer of contamination from one monitoring well to another is also prevented.

Dry-running protection

The $p_{\text{cut-out}}$ value is factory set for SQE and it ensures dry-running protection.

If the speed of the pump is reduced by more than 1000 min^{-1} , the $p_{\text{cut-out}}$ value must be readjusted via CU 300 and Grundfos GO Remote.

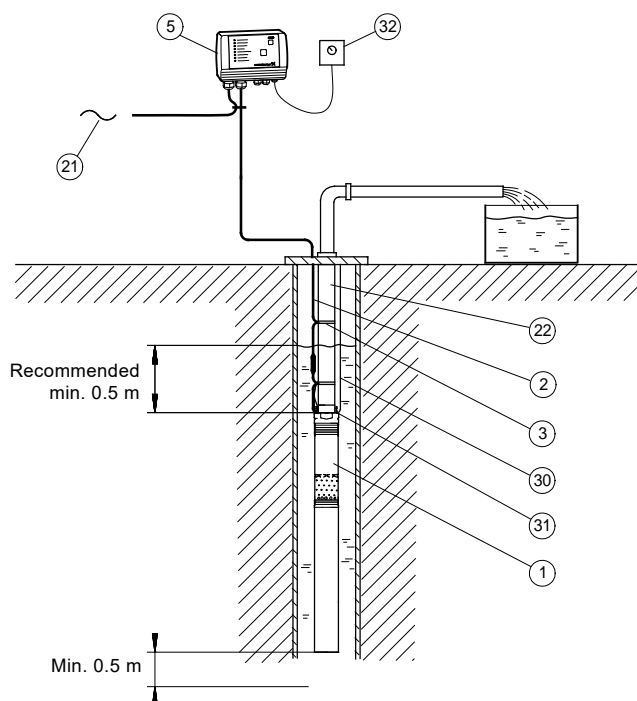

- 1 SQE pump
- 2 Cable
- 3 Cable clips
- 5 CU 300 control unit
- 21 Mains connection, 1 × 220-240 V, 50/60 Hz
- 22 Riser pipe
- 30 Stainless-steel straining wire
- 31 Stainless-steel wire clamps, 2 per lifting eye
- 32 SPP 1 potentiometer

Fig. 16 Manual speed control of the SQE

TN01 9028 4801

Replacement in existing installation

Features and benefits

SQ can be installed as replacement for a 4-inch submersible pump in an existing installation.

When water is consumed, it is taken from the pressure tank without the pump being in operation. If the preset cut-in pressure ($p_{\text{cut-in}}$) is reached, the pump starts operating in the soft-start mode (run-up time approximately 3 seconds). Within this time, the pressure may drop to minimum pressure (p_{min}).

When water consumption stops, the pump builds up system pressure until the preset cut-out pressure ($p_{\text{cut-out}}$) of the pressure switch is reached and the pump is cut out.

At this time the riser pipe between the aerator with non-return valve and the water table is emptied of water. This water is replaced by an amount of air which is pressed to the pressure tank every time the pump starts operating. The air, which serves as an air cushion, is absorbed by the pressure tank or let out to the atmosphere through the vent. It must be tested whether the selected pump can reach $p_{\text{cut-out}} + A$. See [Head losses \(\$H_f\$ \) in plastic pipes and ordinary water pipes](#), on page 30.

The system must be designed for maximum pump pressure.

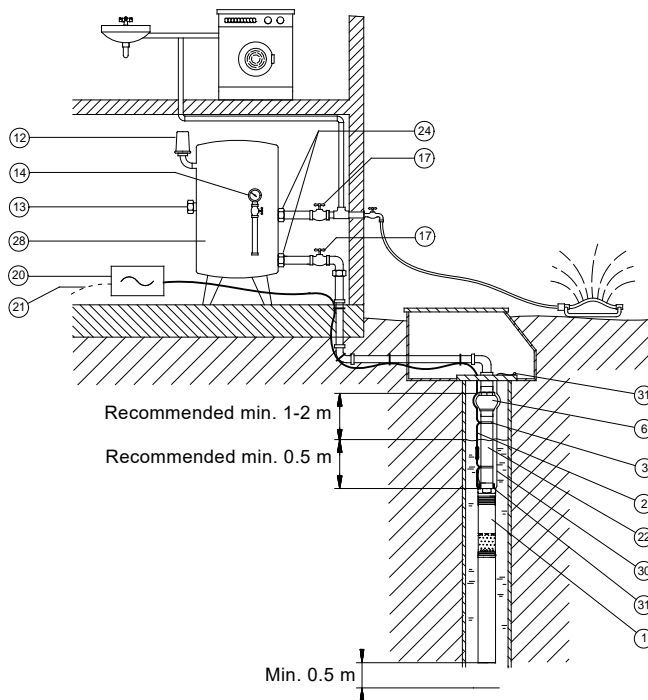

- 1 SQ pump
- 2 Cable
- 3 Cable clips
- 6 Aerator with non-return valve
- 12 Pressure switch
- 13 Vent
- 14 Pressure gauge
- 17 Isolating valve
- 20 Mains switch
- 21 Mains connection, 1 × 200-240 V, 50/60 Hz
- 22 Riser pipe
- 24 Union
- 28 Pressure tank
- 30 Straining wire
- 31 Wire clamp

Note: Do not install draw-off points between the pump and the pressure tank.

Pos. 6: If the aerator remains in the installation, the non-return valve in the SQ pump must be removed.

Fig. 17 Replacement

4. Control units

CU 301 constant pressure control

CU 301 is a control and communication unit specially developed for the SQE submersible pumps in constant-pressure applications.

CU 301 provides the following features:

- full control of SQE
- two-way communication with SQE
- possibility of adjusting the pressure
- alarm indication (LED) when service is needed
- possibility of starting, stopping and resetting the pump by a push-button
- communication with Grundfos GO Remote.

CU 301 communicates with the pump via power-line communication, meaning that no extra cable is required between the CU 301 and the pump.

CU 301 features the following indications (see fig. 18):

1. flow indicator
2. system pressure setting
3. system on/off
4. button lock indicator
5. dry-running indicator
6. service needed in case of:
 - no contact to pump
 - overvoltage
 - undervoltage
 - speed reduction
 - overtemperature
 - overload
 - sensor defective

CU 301 incorporates the following indications:

- external signal input for pressure sensor
- disconnect relay in case of "no contact to pump" or "sensor defective"
- pressure switch mode in case of "no contact to pump" with disconnect relay
- connection to an operating relay for indication of pump operation (changes position after 40 seconds of operation).

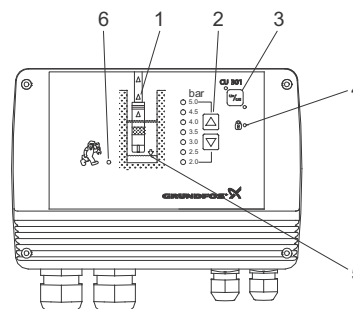

Fig. 18 Front view of CU 301

TM07 7890 4720

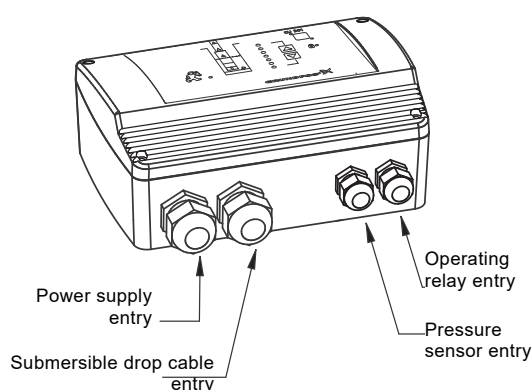
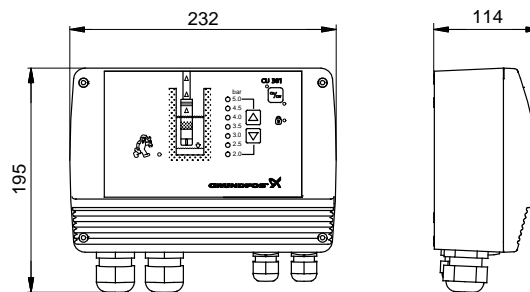

Fig. 19 Cable entries of CU 301

TM02 3427 0406



Dimensions stated in mm.

Fig. 20 Dimensional sketch of CU 301

TM03 3003 5005

Grundfos GO Remote

Grundfos GO Remote enables setting of functions and gives access to status overviews, technical product information and actual operating parameters.

CU 301 is designed for infrared communication with Grundfos GO Remote. Grundfos GO Remote offers the MI 301 mobile interface. See fig. 21.

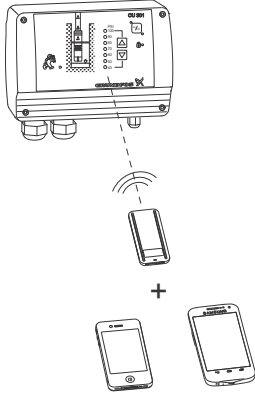

Fig. 21 CU 301 communicating with Grundfos GO Remote

Communication

Grundfos GO Remote is used for wireless infrared communication with CU 301. During communication, there must be visual contact between CU 301 and Grundfos GO Remote. When the communication between Grundfos GO Remote and CU 301 is established, the red indicator light in the on/off button flashes.

TM07 7889 4720

Grundfos GO Remote menus for CU 301

Main menus

Status
Controlled from
Value, sensor 1
Motor temperature
Motor speed
Power consumption
Energy consumption
Operating hours
Number of starts
Settings
Operating mode
Setpoint
Analog input 1
Selection of sensor
Maximum pressure
Automatic restarting
Double restarting time
Dry-running stop
Maximum speed
Cut-in speed
Buttons on product
Number
Indicator lights
Store settings
Recall settings
Undo
Unit configuration
Alarms and warnings
Alarm log
"Reset alarm" button

CU 300 multi-function control

CU 300 is a control and communication unit specially developed for the SQE submersible pumps in constant-pressure applications.

CU 300 provides the following advantages:

- easy adjustment to a specific borehole
- full control of SQE
- two-way communication with SQE
- alarm indication of pump operation by diodes on the front
- possibility of starting, stopping and resetting the pump by a push-button
- communication with Grundfos GO Remote.

CU 300 communicates with the pump via power-line communication, meaning that no extra cables are required between CU 300 and the pump.

The following alarms can be indicated by CU 300:

- no contact
- overvoltage
- undervoltage
- dry running
- speed reduction
- overtemperature
- overload
- sensor alarm.

CU 300 incorporates the following features:

- external signal input for two analog sensors and one digital sensor
- relay output for external alarm indication
- control according to the signals received, for example of flow, pressure, water level and conductivity.

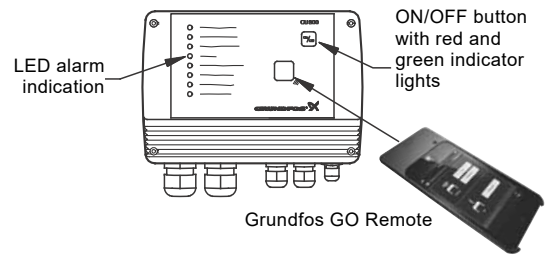

Fig. 22 Front view of CU 300

TM06 2197 3814

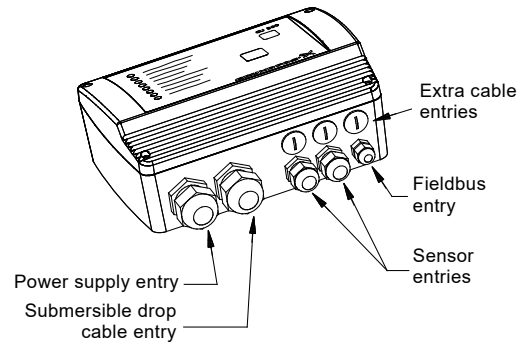
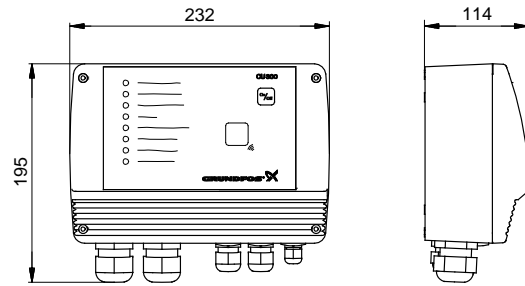

Fig. 23 Cable entries of CU 300

TM01 2761 4801



Dimensions stated in mm.

Fig. 24 Dimensional sketch of CU 300

TM01 2781 4601

Benefits of CU 300 and Grundfos GO Remote

CU 300 and Grundfos GO Remote have the following benefits:

- The status of the connection between the pump and CU 300 is monitored.
- The supply voltage is measured.
- Dry-running protection is provided,
- The pump can operate at a moderate undervoltage and overload, thereby ensuring that the motor is not overloaded.
- The pump stops at a too high temperature, and restarts when the motor electronics have cooled sufficiently.
- Overload protection is provided for the motor.
- Sensor can be connected directly to the CU 300, and the sensor signals are monitored.

Grundfos GO Remote menus for CU 300

Main menus

Status

External setpoint
Controlled from
Motor temperature
Motor speed
Accumulated flow
Power consumption
Energy consumption
Operating hours
Number of starts

Settings

Operating mode
Control mode
Setpoint
Analog input 1
Analog input 2
External setpoint
Warning temperature
Digital input 1
Flow per pulse
Stop limit, accum. flow
Sensor, accum. flow stop
Automatic restarting
Double restarting time
Start delay
Dewatering
Dewatering max. on time
Dewatering max. off time
Dry-running protection
Dry-running stop
Maximum speed
Buttons on product
Number
Store settings
Recall settings
Undo
Unit configuration

Alarms and warnings

Alarm log
Warning log
"Reset alarm" button

Status menu

This menu provides status information only. It is not possible to change settings in this menu.

Accumulated flow

This status item shows the pumped water quantity, and requires connection of an external flowmeter.

Power consumption

This status item shows the actual power consumption of the pump.

Energy consumption

This status item shows the energy consumed by the pump over time.

Operating hours

The number of operating hours and the number of starts are values accumulated from the time of installation and they cannot be reset.

Both values are stored in the motor electronics, and are kept even if CU 300 is replaced.

The number of operating hours is registered every two minutes of continuous operation.

Settings menu

Setpoint

Analog inputs

The analog inputs are used for the connection of sensors. The following parameters are determined in order to set a sensor:

Parameters	Possible settings
Signal type:	Not active, 0-10 V, 2-10 V, 0-20 mA, 4-20 mA.
Sensor unit:	m ³ /h, m, %, GPM, ft.
Minimum:	0-249.
Maximum:	1-250.

5. Pump selection

Determining head and flow

Pump selection is based on the water demand and the required head.

Water demand

These data are normally determined by the manufacturers of fittings and sprinkler systems.

Examples of water demand:

Sprinkler systems: 1.5 m³/h per sprinkler

Domestic water supply: 2-4 m³/h

Agriculture: 4-6 m³/h

Irrigation: 6-8 m³/h

Head

$$H [m] = p_{\text{tap}} \times 10.2 + H_{\text{geo}} + H_f$$

p_{tap} = required pressure at the draw-off point (for example sprinkler), at least 2 bar

H_{geo} = difference of height between lower water level in well and draw-off point

H_f = loss of head in piping and tubing

For selection of H_f , see [Pump sizing](#), page 26.

Example of calculation

Application: domestic water supply.

Required flow: 2.4 m³/h

$p_{\text{tap}} = 3$ bar

$H_{\text{geo}} = 30$ m

$H_f = 7.7$ m

The tubing is made of a 35-metre plastic pipe of 25 mm diameter.

This will give the following:

$H_f = \text{value from table} \times \text{length of pipe}$

$H_f = 0.22 \times 35 \text{ m} = 7.7 \text{ m}$

$H [m] = p_{\text{tap}} \times 10.2 + H_{\text{geo}} + H_f$

$= 3 \times 10.2 + 30 \text{ m} + 7.7 = 68.3 \text{ m}$

Selected at Q = 2.4 m³/h, H = 68.3 m

For selection of the pump type best meeting the requirements, see [Pump sizing](#), page 26.

Pump sizing

Important: The dry-running protection is effective only within the recommended duty range of the pump, indicated by the bold curves. See performance curves.

Pump type	Input power (P1) [kW]	Flow rate Q [m ³ /h] / [l/s]													Max. head [m] (Q = 0 m ³ /h)	Rated current I _{1/1} [A]		Pipe connection Rp
		0.5/0.14	1.0/0.28	1.5/0.42	2.0/0.56	2.5/0.70	3.0/0.83	3.5/0.97	4.0/1.11	5.0/1.39	6.0/1.67	7.0/1.95	8.0/2.22	9.0/2.50		230 V 200 V		
		Head [m]																
SQ 1-35	0.58	43	34	20	-	-	-	-	-	-	-	-	-	-	47	2.5	2.9	1 1/4
SQ 1-50	0.78	65	52	32	-	-	-	-	-	-	-	-	-	-	71	3.3	4.0	1 1/4
SQ 1-65	1.00	88	70	44	-	-	-	-	-	-	-	-	-	-	94	4.3	5.2	1 1/4
SQ 1-80	1.18	110	89	56	-	-	-	-	-	-	-	-	-	-	118	5.1	6.0	1 1/4
SQ 1-95	1.38	132	107	68	-	-	-	-	-	-	-	-	-	-	142	6.0	7.0	1 1/4
SQ 1-110	1.59	155	125	80	-	-	-	-	-	-	-	-	-	-	166	7.0	8.1	1 1/4
SQ 1-125	1.82	177	144	93	-	-	-	-	-	-	-	-	-	-	189	7.8	9.3	1 1/4
SQ 1-140	2.02	199	162	104	-	-	-	-	-	-	-	-	-	-	213	8.6	10.3	1 1/4
SQ 1-155	2.19	222	180	117	-	-	-	-	-	-	-	-	-	-	237	9.6	11.0	1 1/4
SQ 2-35	0.71	43	42	39	35	29	19	-	-	-	-	-	-	-	45	3.0	3.6	1 1/4
SQ 2-55	1.00	66	63	60	54	45	32	-	-	-	-	-	-	-	68	4.3	5.2	1 1/4
SQ 2-70	1.27	87	84	79	72	60	43	-	-	-	-	-	-	-	89	5.5	6.4	1 1/4
SQ 2-85	1.55	108	105	99	89	74	54	-	-	-	-	-	-	-	109	6.8	7.9	1 1/4
SQ 2-100	1.86	131	128	120	109	91	67	-	-	-	-	-	-	-	132	8.0	9.5	1 1/4
SQ 2-115	2.11	154	150	142	129	108	79	-	-	-	-	-	-	-	155	9.3	10.6	1 1/4
SQ 3-30	0.70	-	-	34	32	30	26	22	-	-	-	-	-	-	36	3.0	3.6	1 1/4
SQ 3-40	0.99	-	-	53	50	47	42	36	-	-	-	-	-	-	56	4.2	5.1	1 1/4
SQ 3-55	1.25	-	-	70	67	63	56	48	-	-	-	-	-	-	74	5.4	6.6	1 1/4
SQ 3-65	1.52	-	-	87	83	78	70	60	-	-	-	-	-	-	92	6.7	7.8	1 1/4
SQ 3-80	1.82	-	-	105	100	94	85	73	-	-	-	-	-	-	110	7.8	9.3	1 1/4
SQ 3-95	2.09	-	-	123	117	109	99	85	-	-	-	-	-	-	129	9.0	10.7	1 1/4
SQ 3-105	2.33	-	-	140	134	125	113	97	-	-	-	-	-	-	147	10.3	11.7	1 1/4
SQ 5-15	0.53	-	-	-	-	-	15	14	13	11	7	-	-	-	18	2.3	2.7	1 1/2
SQ 5-25	0.92	-	-	-	-	-	31	29	28	24	18	-	-	-	36	3.9	4.7	1 1/2
SQ 5-35	1.29	-	-	-	-	-	46	44	42	36	28	-	-	-	54	5.6	6.5	1 1/2
SQ 5-50	1.70	-	-	-	-	-	62	59	56	49	38	-	-	-	71	7.3	8.7	1 1/2
SQ 5-60	2.08	-	-	-	-	-	77	74	70	61	48	-	-	-	89	8.9	10.6	1 1/2
SQ 5-70	2.43	-	-	-	-	-	93	89	85	73	58	-	-	-	106	10.7	12.0	1 1/2
SQ 7-15	0.73	-	-	-	-	-	-	17	16	14	12	9	6	2	21	3.1	3.7	1 1/2
SQ 7-30	1.26	-	-	-	-	-	-	36	35	32	29	24	18	10	42	5.5	6.4	1 1/2
SQ 7-40	1.81	-	-	-	-	-	-	56	54	50	45	38	29	19	64	7.8	9.3	1 1/2

Example

Required:

Flow rate: 2.4 m³/h

The nearest higher value in the table is 2.5 m³/h.

Head: 68.3 m

The nearest higher value in the table is 78 m.

Selected:

Pump type: SQ 3-65 (as it offers the best pump efficiency for the required flow and head).

Required pump power input: 1.52 kW

Rated current: I_{1/1} = 6.7 A at 230 V
I_{1/1} = 7.8 A at 200 V

Pipe connection: Rp 1 1/4

Length of pump: 826 mm

How to select an SQ pump

- A head of 68 m and a flow of 2.4 m³/h are required.
- The pump type best meeting these requirements is SQ 3. In the curve chart below, draw a rightward horizontal line from the head required 68 m (1) to the intersection with the vertical line from the required flow (2). In this example, the intersection (3) of the two lines is not on one of the pump curves, therefore, follow the pipe characteristic upwards. The intersection of the pump curve and the pipe characteristic (4) gives the size of the pump. The size of the pump is SQ 3-65.
- The pump power input per stage (P2) can be read 0.20 kW (5), and the pump efficiency per stage is 57 % (6).

SQ 3-65 has 5 stages. See page 35. With 5 stages, the total pump power input for SQ 3-65 is 1.02 kW, (0.20 kW multiplied by 5), which corresponds to an MS 3 1.15 kW motor.

Selection of pressure tank

The electronic unit in the SQ pump ensures a smooth startup. To yield sufficient pressurised water in the period when the pump is not in operation, a pressure tank can be installed in the water supply system.

During startup, the system pressure falls below the cut-in pressure of the pressure switch. This value (p_{min}) is to be determined before sizing the pressure tank.

p_{min} is the required minimum pressure at the highest tap point plus head and valve and friction loss from the pressure tank to the highest tap point (C + B).

Furthermore, the flow at p_{min} has to be determined. This is called Q_{max} and is found in the performance curve for the pump type in question.

Use p_{min} and Q_{max} in the table below to find the size of the pressure tank, the precharge pressure of the pressure tank and the cut-in and cut-out pressure settings of the pressure switch.

Note: If a minimum pressure is not required, an 18-litre pressure tank is sufficient for all SQ pumps.

Ensure that the selected pump can deliver a pressure higher than $p_{cut-out} + A$.

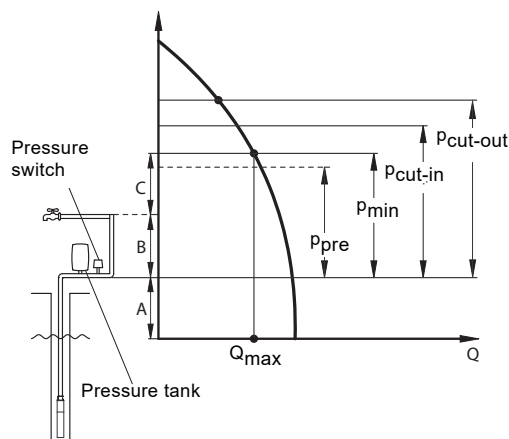

Fig. 25 System with pressure tank

- p_{pre} : precharge pressure of the pressure tank
- p_{min} : required minimum pressure
- p_{cut-in} : cut-in pressure of the pressure switch
- $p_{cut-out}$: cut-out pressure of the pressure switch
- Q_{max} : flow at p_{min}
- A: head plus pipe friction loss from dynamic water level to pressure tank
- B: head plus pipe friction loss from pressure tank to the top tap point
- C: minimum pressure at the highest point.

TM00 6445 3795

p_{min} [m]	Q_{max} [m ³ /h]																p_{pre} [m]	p_{cut-in} [m]	$p_{cut-out}$ [m]			
	0.6	0.8	1	1.2	1.5	2	2.5	3	3.5	4	4.5	5	5.5	6	6.5	7				7.5	8	
Pressure tank size [litres]																						
25	8	8	18	18	18	18	24	33	33	50	50	50	80	80	80	80	80	22.5	26	40		
30	8	8	18	18	18	24	33	33	50	50	50	50	80	80	80	80	80	27	31	45		
35	8	18	18	18	18	24	33	33	50	50	50	80	80	80	80	80		31.5	36	50		
40	8	18	18	18	18	24	33	50	50	50	80	80	80	80	80			36	41	55		
45	8	18	18	18	24	33	33	50	50	50	80	80	80	80				40.5	46	60		
50	8	18	18	18	24	33	50	50	50	80	80	80	80					45	51	65		
55	18	18	18	18	24	33	50	50	50	80	80	80						49.5	56	70		
60	18	18	18	18	24	33	50	50	80	80	80	80						54	61	75		
65	18	18	18	24	24	33	50	50	80	80	80	80						58.5	66	80		

Note: The pressure tank sizes stated in the table are minimum requirements. We recommend that you use a tank one size bigger.

1 m head = 0.098 bar

Example

$p_{min} = 45$ m, $Q_{max} = 2.5$ m³/h

The following values are found in the table:

Minimum size of pressure tank = 33 litres

$p_{pre} = 40.5$ m

$p_{cut-in} = 46$ m

$p_{cut-out} = 60$ m.

Example

How to select an SQE pump

The procedure for selecting an SQE pump is identical to the procedure for selecting an SQ pump.

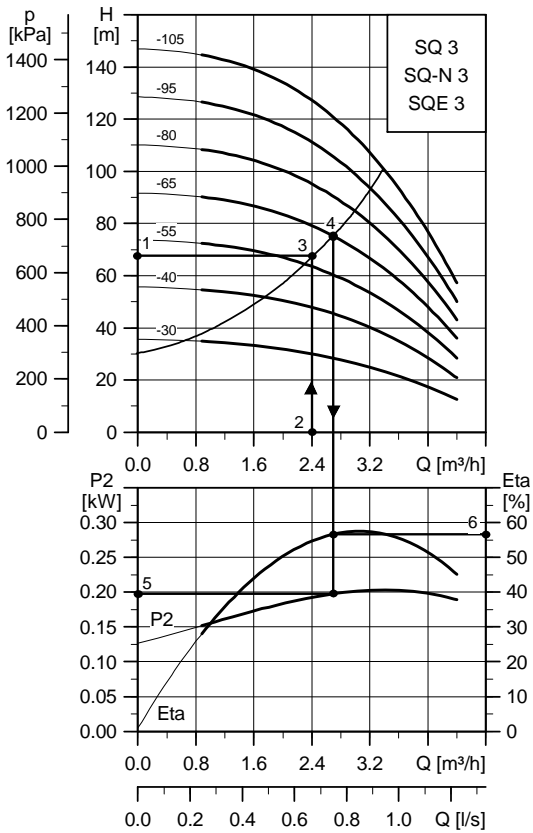

Fig. 26 Pump selection in steps

TM01 3046 4801

Variable speed

The performance of the SQE pump can be adjusted to a specific duty point within its performance range. This is done via CU 300 or CU 301 and Grundfos GO Remote.

The SQE pump is especially ideal in cases when the water consumption varies over time, or the duty point is between two pump curves, as energy savings can be achieved by reducing the performance to the required speed. Figure 27 shows the performance of an SQE 5-70 pump at various speeds.

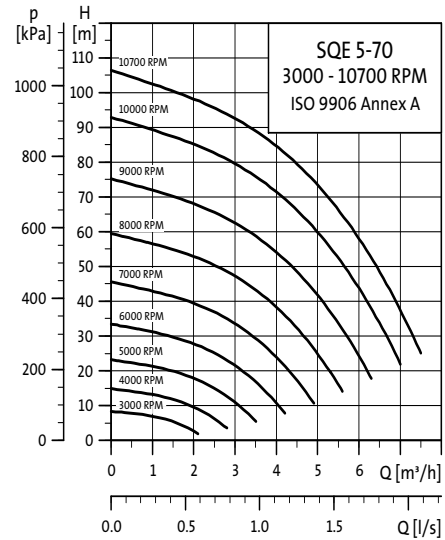

Fig. 27 Performance curve at various speeds

TM01 3220 4304

Selecting the right pump for the SQE constant-pressure system

Dynamic head [m]	Rated flow [m ³ /h]	System pressure [bar]						
		2.0	2.5	3.0	3.5 (C)	4.0	4.5	5.0
10 to 20	2	← SQE 2-55 →		← SQE 2-85 →			← SQE 2-85 →	
	2	← SQE 2-55 →		← SQE 2-85 →			← SQE 2-85 →	
	3	← SQE 5-50 →		← SQE 3-65 →			← SQE 3-65 →	
	5	← SQE 5-50 →		← SQE 5-70 →			← SQE 5-70 →	
21 to 30 (A)	2	← SQE 2-55 →		← SQE 2-85 →			← SQE 2-85 →	
	2	← SQE 2-55 →		← SQE 2-85 →			← SQE 2-85 →	
	3 (B)	← SQE 3-65 →		← SQE 3-65 (D) →			← SQE 3-105 →	
	5	← SQE 5-70 →		← SQE 5-70 →			← SQE 3-105 →	
31 to 40	2	← SQE 2-85 →		← SQE 2-85 →			← SQE 2-115 →	
	2	← SQE 2-85 →		← SQE 2-85 →			← SQE 2-115 →	
	3	← SQE 3-65 →		← SQE 3-65 →			← SQE 3-105 →	
	3	← SQE 3-65 →		← SQE 3-105 →			← SQE 3-105 →	
41 to 50	2	← SQE 2-85 →		← SQE 2-85 →			← SQE 2-115 →	
	2	← SQE 2-85 →		← SQE 2-85 →			← SQE 2-115 →	
	3	← SQE 3-105 →		← SQE 3-105 →			← SQE 3-105 →	
51 to 60	2	← SQE 2-115 →		← SQE 2-115 →			← SQE 2-115 →	
	3	← SQE 3-105 →		← SQE 3-105 →			← SQE 3-105 →	
61 to 70	2	← SQE 2-115 →		← SQE 2-115 →			← SQE 2-115 →	
	3	← SQE 3-105 →		← SQE 3-105 →			← SQE 3-105 →	
71 to 80	2	← SQE 2-115 →		← SQE 2-115 →			← SQE 2-115 →	
81 to 90	2	← SQE 2-115 →		← SQE 2-115 →			← SQE 2-115 →	

How to select an SQE pump

Example

Required:

Total head (from water level to water tap, including friction loss): 25 m (A).

Maximum flow rate: 3 m³/h (B).

System pressure: 3.5 bar (C).

Selected:

Pump type: SQE 3-65.

The system pressure can be adjusted to any constant pressure from 2 to 4 bars (D).

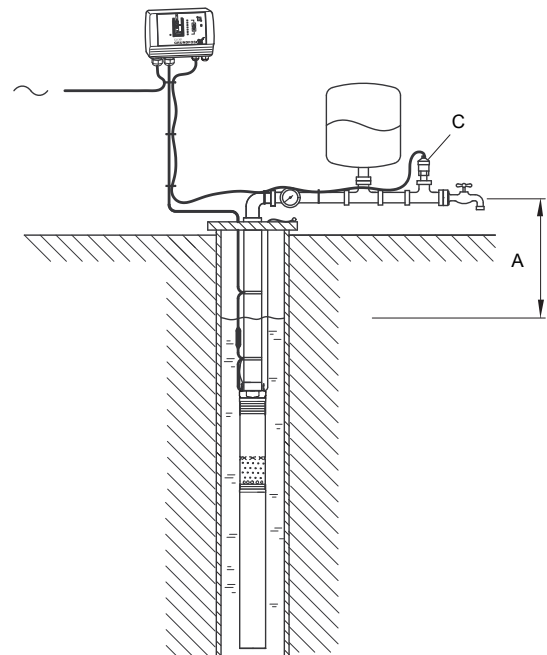

Fig. 28 Parameters A and C for selection of an SQE pump

TM03 3431 0406

Head losses (H_f) in plastic pipes and ordinary water pipes

Upper figures indicate the velocity of water in metre per secundum (m/s).

Lower figures indicate head loss in metres per 100 metres of straight pipes.

Quantity of water			Plastic pipes ¹ (PELM/PEH PN 10 PELM)				Ordinary water pipes ²				
m ³ /h	Litres/min.	Litres/sec.	Nominal pipe diameter and internal diameter in mm				Nominal pipe diameter in inches and internal diameter in mm				
			25 20.4	32 26.2	40 32.6	50 40.8	1/2 15.75	3/4 21.25	1 27.00	1 1/4 35.75	1 1/2 41.25
0.6	10	0.16	0.49 1.8	0.30 0.66	0.19 0.27	0.12 0.085	0.855 9.910	0.470 2.407	0.292 0.784	-	-
0.9	15	0.25	0.76 4.0	0.46 1.14	0.3 0.6	0.19 0.18	1.282 20.11	0.705 4.862	0.438 1.570	0.249 0.416	-
1.2	20	0.33	1.0 6.4	0.61 2.2	0.39 0.9	0.25 0.28	1.710 33.53	0.940 8.035	0.584 2.588	0.331 0.677	0.249 0.346
1.5	25	0.42	1.3 10.0	0.78 3.5	0.5 1.4	0.32 0.43	2.138 49.93	1.174 11.91	0.730 3.834	0.415 1.004	0.312 0.510
1.8	30	0.50	1.53 13.0	0.93 4.6	0.6 1.9	0.38 0.57	2.565 69.34	1.409 16.50	0.876 5.277	0.498 1.379	0.374 0.700
2.1	35	0.58	1.77 16.0	1.08 6.0	0.69 2.0	0.44 0.70	2.993 91.54	1.644 21.75	1.022 6.949	0.581 1.811	0.436 0.914
2.4	40	0.67	2.05 22.0	1.24 7.5	0.80 3.3	0.51 0.93	-	1.879 27.66	1.168 8.820	0.664 2.290	0.499 1.160
3.0	50	0.83	2.54 37.0	1.54 11.0	0.99 4.8	0.63 1.40	-	2.349 41.40	1.460 13.14	0.830 3.403	0.623 1.719
3.6	60	1.00	3.06 43.0	1.85 15.0	1.2 6.5	0.76 1.90	-	2.819 57.74	1.751 18.28	0.996 4.718	0.748 2.375
4.2	70	1.12	3.43 50.0	2.08 18.0	1.34 8.0	0.86 2.50	-	3.288 76.49	2.043 24.18	1.162 6.231	0.873 3.132
4.8	80	1.33	-	2.47 25.0	1.59 10.5	1.02 3.00	-	-	2.335 30.87	1.328 7.940	0.997 3.988
5.4	90	1.50	-	2.78 30.0	1.8 12.0	1.15 3.50	-	-	2.627 38.30	1.494 9.828	1.122 4.927
6.0	100	1.67	-	3.1 39.0	2.0 16.0	1.28 4.6	-	-	2.919 46.49	1.660 11.90	1.247 5.972
7.5	125	2.08	-	3.86 50.0	2.49 24.0	1.59 6.6	-	-	3.649 70.41	2.075 17.93	1.558 8.967
9.0	150	2.50	-	-	3.00 33.0	1.91 8.6	-	-	-	2.490 25.11	1.870 12.53
10.5	175	2.92	-	-	3.5 38.0	2.23 11.0	-	-	-	2.904 33.32	2.182 16.66
90 ° bends, slide valves							1.0	1.0	1.1	1.2	1.3
T-pieces, non-return valves							4.0	4.0	4.0	5.0	5.0

¹ The table is based on a nomogram. Roughness: $K = 0.01$ mm. Water temperature: $t = 10$ °C.

² The data are calculated in accordance with H. Lang's new formula $a = 0.02$, and for a water temperature of 10 °C. The head loss in bends, slide valves, T-pieces and non-return valves is equivalent to the metres of straight pipes stated in the last two lines of the table.

Curve conditions

The guidelines below apply to the performance curves on pages 31 to 43:

- Tolerances are according to ISO 9906: 2012 Grade 3, thus all curves show mean values.
- The curves must not be used as guarantee curves.
- The bold curves show the recommended duty range.
- The measurements were made with airless water at a temperature of 20 °C.
- The conversion between head H [m] and pressure p [kPa] applies to water with a density of 1,000 kg/m³.
- The curves apply to a kinematic viscosity of 1 mm²/s (1 cSt). If the pump is used for liquids with a viscosity higher than that of water, it will reduce the head and increase the power consumption.
- Q/H: The curves include valve and inlet losses at the actual speed.
- Power curve: P2 shows pump power input per stage.
- Efficiency curve: Eta shows pump efficiency per stage.

6. Performance curves and technical data

SQ 1, SQ 1-N, SQE 1, SQE 1-N

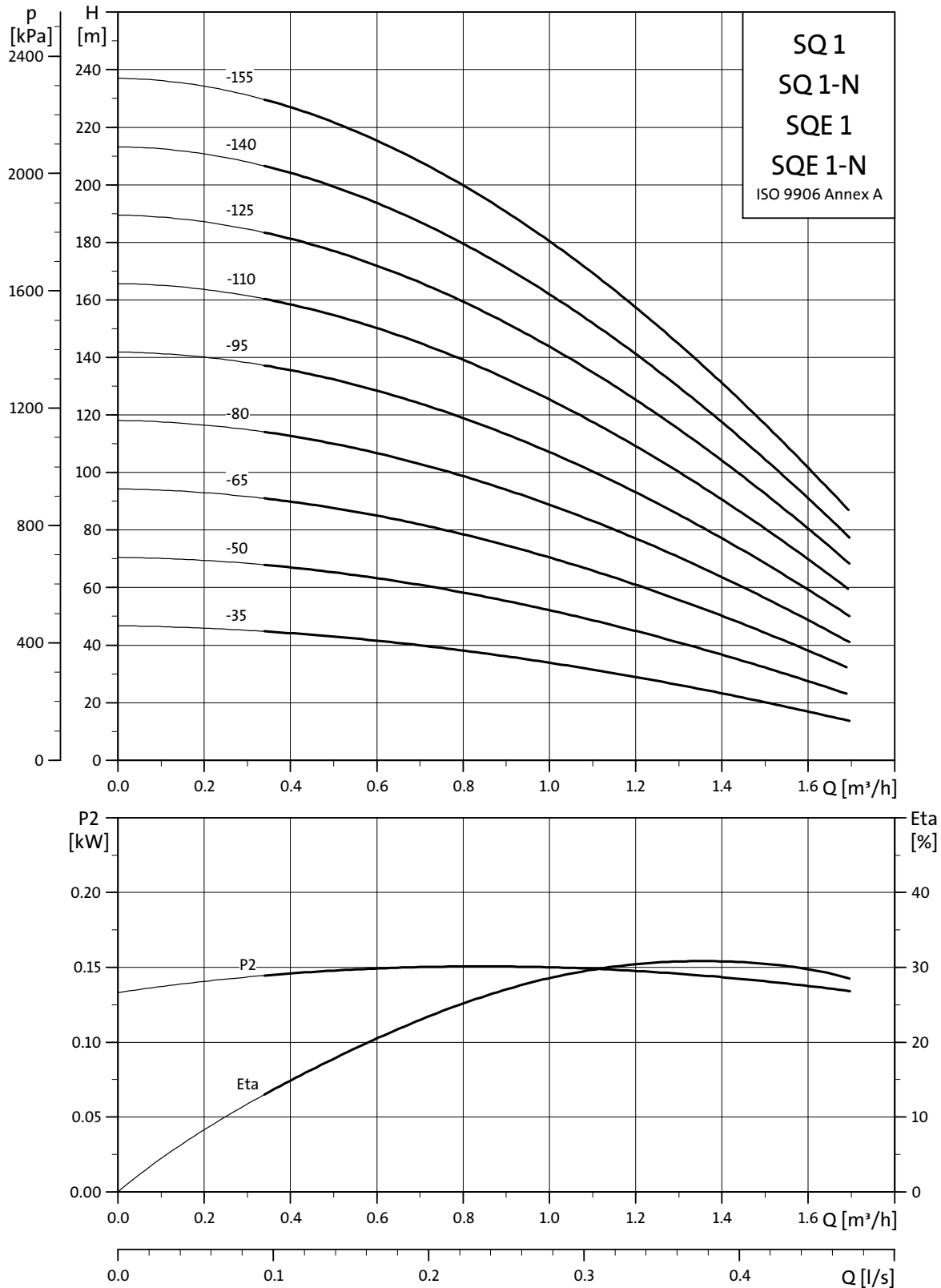

TM01 2692 4304

Dimensions and weights

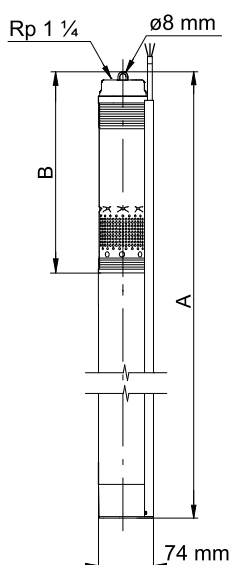

TM01 2752 0499

Pump type	Number of stages	Motor		Dimensions [mm]		Net weight [kg] ¹	Shipping volume [m ³] ¹
		Type	Output power (P2) [kW]	A	B		
SQ 1-35 (-N)	2	MS 3 (-NE)	0.70	741	265	4.7	0.0092
SQE 1-35 (-N)		MSE 3 (-NE)					
SQ 1-50 (-N)	3	MS 3 (-NE)	0.70	741	265	4.8	0.0092
SQE 1-50 (-N)		MSE 3 (-NE)					
SQ 1-65 (-N)	4	MS 3 (-NE)	0.70	768	292	4.9	0.0094
SQE 1-65 (-N)		MSE 3 (-NE)					
SQ 1-80 (-N)	5	MS 3 (-NE)	1.15	825	346	5.6	0.0100
SQE 1-80 (-N)		MSE 3 (-NE)					
SQ 1-95 (-N)	6	MS 3 (-NE)	1.15	825	346	5.6	0.0100
SQE 1-95 (-N)		MSE 3 (-NE)					
SQ 1-110 (-N)	7	MS 3 (-NE)	1.15	852	373	5.7	0.0103
SQE 1-110 (-N)		MSE 3 (-NE)					
SQ 1-125 (-N)	8	MS 3 (-NE)	1.55	942	427	6.4	0.0113
SQE 1-125 (-N)		MSE 3 (-NE)					
SQ 1-140 (-N)	9	MS 3 (-NE)	1.55	942	427	6.5	0.0113
SQE 1-140 (-N)		MSE 3 (-NE)					
SQ 1-155 (-N)	10	MS 3 (-NE)	1.85	969	454	6.7	0.0116
SQE 1-155 (-N)		MSE 3 (-NE)					

¹ Including pump, motor, 1.5-metre cable and cable guard.

Electrical data, 1 × 200-240 V, 50/60 Hz

Pump type	Motor type	Input power, motor (P1) [kW]	Output power, motor (P2) [kW]	Required input power, pump [kW]	Rated current I _{1/1} [A]		Rated motor efficiency (η) [%]
					230 V	200 V	
SQ 1-35 (-N)	MS 3 (-NE)	0.58	0.70	0.37	2.5	2.9	70
SQE 1-35 (-N)	MSE 3 (-NE)						
SQ 1-50 (-N)	MS 3 (-NE)	0.78	0.70	0.52	3.3	4.0	70
SQE 1-50 (-N)	MSE 3 (-NE)						
SQ 1-65 (-N)	MS 3 (-NE)	1.00	0.70	0.68	4.3	5.2	70
SQE 1-65 (-N)	MSE 3 (-NE)						
SQ 1-80 (-N)	MS 3 (-NE)	1.18	1.15	0.84	5.1	6.0	73
SQE 1-80 (-N)	MSE 3 (-NE)						
SQ 1-95 (-N)	MS 3 (-NE)	1.38	1.15	0.99	6.0	7.0	73
SQE 1-95 (-N)	MSE 3 (-NE)						
SQ 1-110 (-N)	MS 3 (-NE)	1.59	1.15	1.15	7.0	8.1	73
SQE 1-110 (-N)	MSE 3 (-NE)						
SQ 1-125 (-N)	MS 3 (-NE)	1.82	1.55	1.31	7.8	9.3	74
SQE 1-125 (-N)	MSE 3 (-NE)						
SQ 1-140 (-N)	MS 3 (-NE)	2.02	1.55	1.47	8.6	10.3	74
SQE 1-140 (-N)	MSE 3 (-NE)						
SQ 1-155 (-N)	MS 3 (-NE)	2.19	1.85	1.62	9.6	11.0	74
SQE 1-155 (-N)	MSE 3 (-NE)						

SQ 2, SQ 2-N, SQE 2, SQE 2-N

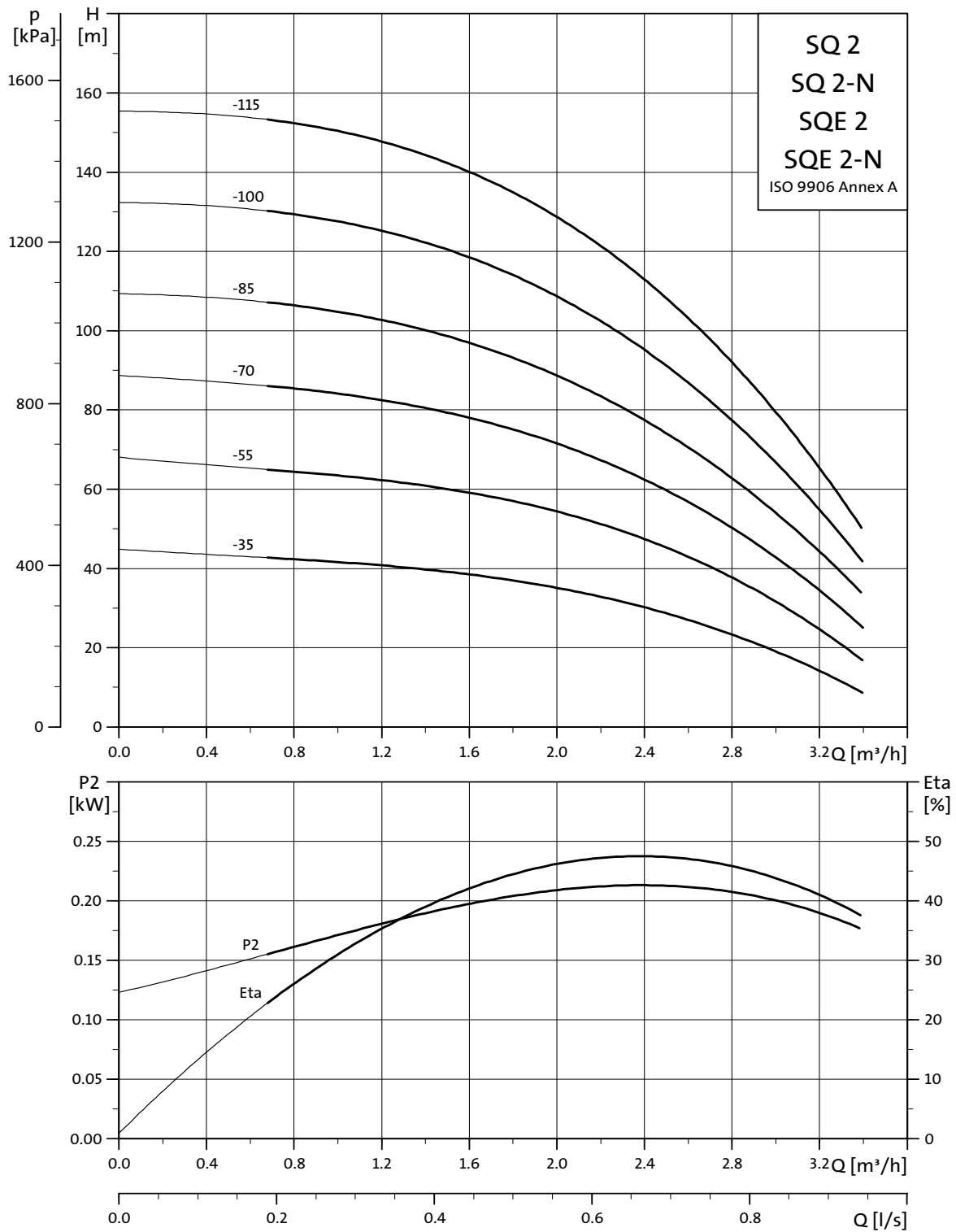

TM01 2693 4304

Dimensions and weights

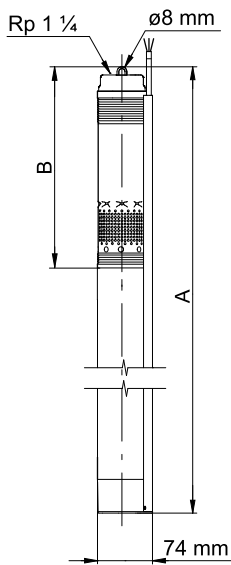

TM01 2752 0499

Pump type	Number of stages	Motor		Dimensions [mm]		Net weight [kg] ¹	Shipping volume [m ³] ¹
		Type	Output power (P2) [kW]	A	B		
SQ 2-35 (-N)	2	MS 3 (-NE)	0.70	741	265	4.7	0.0092
SQE 2-35 (-N)		MSE 3 (-NE)					
SQ 2-55 (-N)	3	MS 3 (-NE)	0.70	741	265	4.8	0.0092
SQE 2-55 (-N)		MSE 3 (-NE)					
SQ 2-70 (-N)	4	MS 3 (-NE)	1.15	768	292	5.4	0.0094
SQE 2-70 (-N)		MSE 3 (-NE)					
SQ 2-85 (-N)	5	MS 3 (-NE)	1.15	825	346	5.5	0.0100
SQE 2-85 (-N)		MSE 3 (-NE)					
SQ 2-100 (-N)	6	MS 3 (-NE)	1.55	861	346	6.2	0.0104
SQE 2-100 (-N)		MSE 3 (-NE)					
SQ 2-115 (-N)	7	MS 3 (-NE)	1.85	888	373	6.3	0.0107
SQE 2-115 (-N)		MSE 3 (-NE)					

¹ Including pump, motor, 1.5-metre cable and cable guard.

Electrical data, 1 × 200-240 V, 50/60 Hz

Pump type	Motor type	Input power, motor (P1) [kW]	Output power, motor (P2) [kW]	Required input power, pump [kW]	Rated current I _{1/1} [A]		Rated motor efficiency (η) [%]
					230 V	200 V	
SQ 2-35 (-N)	MS 3 (-NE)	0.71	0.70	0.47	3.0	3.6	70
SQE 2-35 (-N)	MSE 3 (-NE)						
SQ 2-55 (-N)	MS 3 (-NE)	1.00	0.70	0.69	4.3	5.2	70
SQE 2-55 (-N)	MSE 3 (-NE)						
SQ 2-70 (-N)	MS 3 (-NE)	1.27	1.15	0.91	5.5	6.4	73
SQE 2-70 (-N)	MSE 3 (-NE)						
SQ 2-85 (-N)	MS 3 (-NE)	1.55	1.15	1.13	6.8	7.9	73
SQE 2-85 (-N)	MSE 3 (-NE)						
SQ 2-100 (-N)	MS 3 (-NE)	1.86	1.55	1.35	8.0	9.5	74
SQE 2-100 (-N)	MSE 3 (-NE)						
SQ 2-115 (-N)	MS 3 (-NE)	2.11	1.85	1.57	9.3	10.6	74
SQE 2-115 (-N)	MSE 3 (-NE)						

SQ 3, SQ 3-N, SQE 3, SQE 3-N

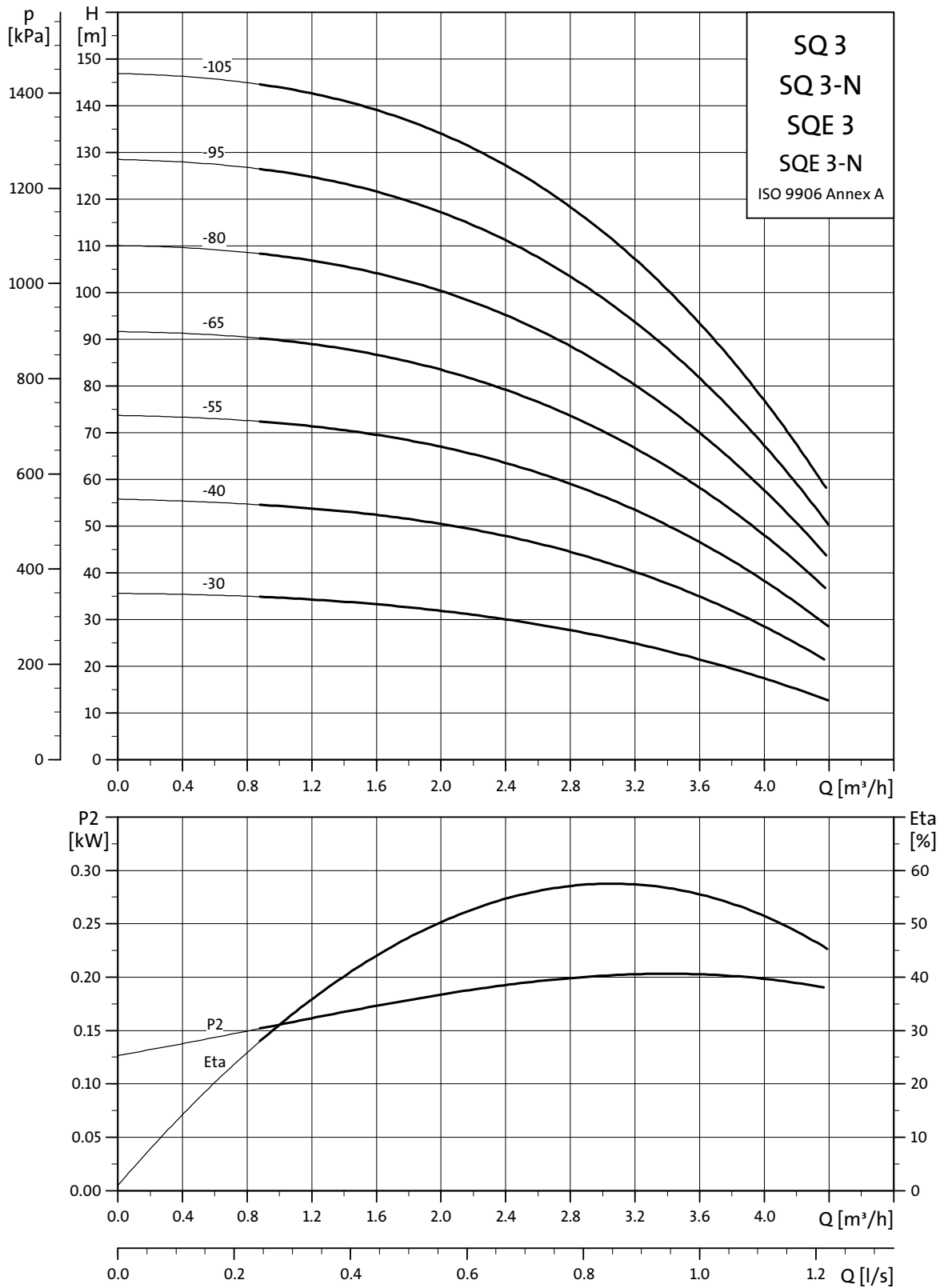

TM01 2694 4304

Dimensions and weights

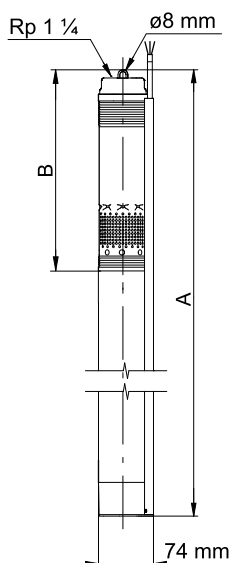

TM01 2752 0499

Pump type	Number of stages	Motor		Dimensions [mm]		Net weight [kg] ¹	Shipping volume [m ³] ¹
		Type	Output power (P2) [kW]	A	B		
SQ 3-30 (-N)	2	MS 3 (-NE)	0.70	741	265	4.8	0.0092
SQE 3-30 (-N)		MSE 3 (-NE)					
SQ 3-40 (-N)	3	MS 3 (-NE)	0.70	741	265	4.8	0.0092
SQE 3-40 (-N)		MSE 3 (-NE)					
SQ 3-55 (-N)	4	MS 3 (-NE)	1.15	768	292	5.4	0.0094
SQE 3-55 (-N)		MSE 3 (-NE)					
SQ 3-65 (-N)	5	MS 3 (-NE)	1.15	825	346	6.1	0.0100
SQE 3-65 (-N)		MSE 3 (-NE)					
SQ 3-80 (-N)	6	MS 3 (-NE)	1.55	861	346	6.3	0.0104
SQE 3-80 (-N)		MSE 3 (-NE)					
SQ 3-95 (-N)	7	MS 3 (-NE)	1.55	888	373	6.4	0.0107
SQE 3-95 (-N)		MSE 3 (-NE)					
SQ 3-105 (-N)	8	MS 3 (-NE)	1.85	942	427	6.5	0.0113
SQE 3-105 (-N)		MSE 3 (-NE)					

¹ Including pump, motor, 1.5-metre cable and cable guard.

Electrical data, 1 × 200-240 V, 50/60 Hz

Pump type	Motor type	Input power, motor (P1) [kW]	Output power, motor (P2) [kW]	Required input power, pump [kW]	Rated current I _{1/1} [A]		Rated motor efficiency (η) [%]
					230 V	200 V	
SQ 3-30 (-N)	MS 3 (-NE)	0.70	0.70	0.46	3.0	3.6	70
SQE 3-30 (-N)	MSE 3 (-NE)						
SQ 3-40 (-N)	MS 3 (-NE)	0.99	0.70	0.68	4.2	5.1	70
SQE 3-40 (-N)	MSE 3 (-NE)						
SQ 3-55 (-N)	MS 3 (-NE)	1.25	1.15	0.89	5.4	6.3	73
SQE 3-55 (-N)	MSE 3 (-NE)						
SQ 3-65 (-N)	MS 3 (-NE)	1.52	1.15	1.10	6.7	7.8	73
SQE 3-65 (-N)	MSE 3 (-NE)						
SQ 3-80 (-N)	MS 3 (-NE)	1.82	1.55	1.31	7.8	9.3	74
SQE 3-80 (-N)	MSE 3 (-NE)						
SQ 3-95 (-N)	MS 3 (-NE)	2.09	1.55	1.52	9.0	10.7	74
SQE 3-95 (-N)	MSE 3 (-NE)						
SQ 3-105 (-N)	MS 3 (-NE)	2.33	1.85	1.74	10.3	11.7	74
SQE 3-105 (-N)	MSE 3 (-NE)						

SQ 5, SQ 5-N, SQE 5, SQE 5-N

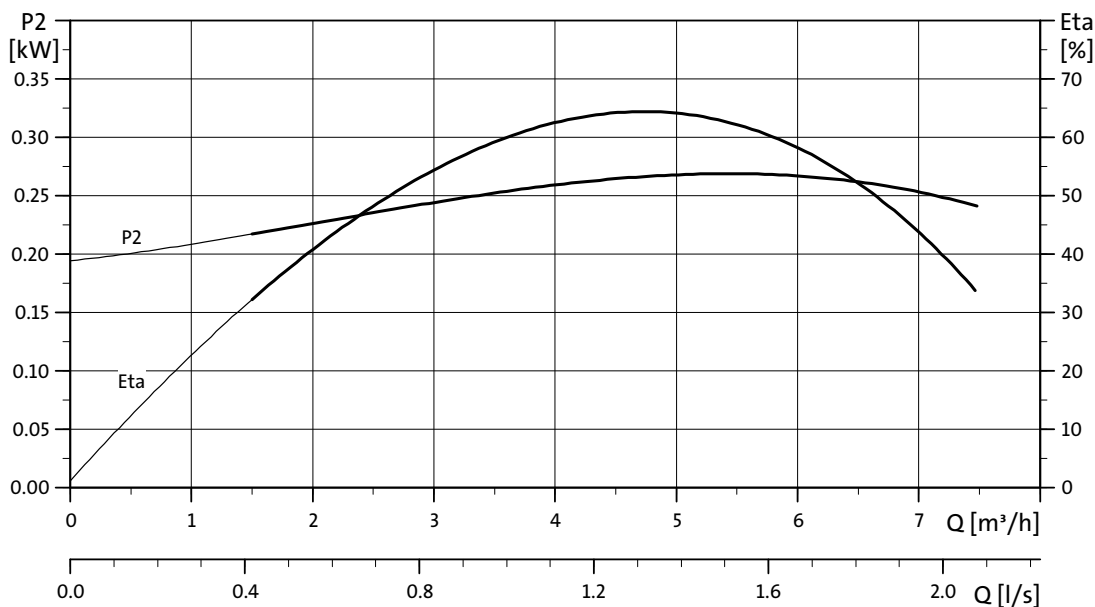
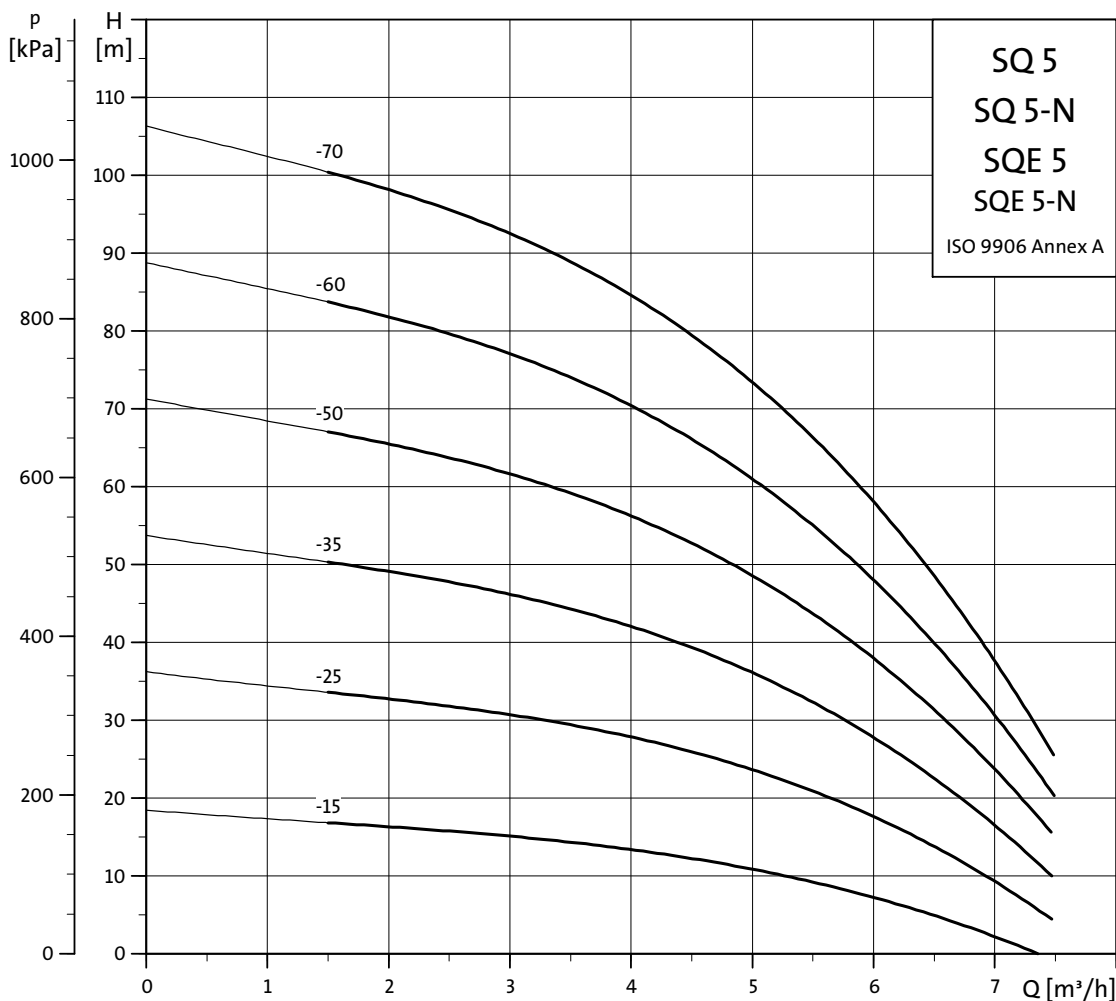

TN01 2695 4304

Dimensions and weights

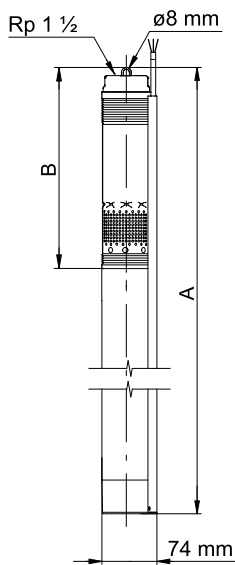

TM01 2759 0499

Pump type	Number of stages	Motor		Dimensions [mm]		Net weight [kg] ¹	Shipping volume [m ³] ¹
		Type	Output power (P2) [kW]	A	B		
SQ 5-15 (-N)	1	MS 3 (-NE)	0.70	743	265	4.7	0.0092
SQE 5-15 (-N)		MSE 3 (-NE)					
SQ 5-25 (-N)	2	MS 3 (-NE)	0.70	743	265	4.8	0.0092
SQE 5-25 (-N)		MSE 3 (-NE)					
SQ 5-35 (-N)	3	MS 3 (-NE)	1.15	824	346	5.5	0.0100
SQE 5-35 (-N)		MSE 3 (-NE)					
SQ 5-50 (-N)	4	MS 3 (-NE)	1.55	860	346	6.1	0.0104
SQE 5-50 (-N)		MSE 3 (-NE)					
SQ 5-60 (-N)	5	MS 3 (-NE)	1.55	941	427	6.4	0.0113
SQE 5-60 (-N)		MSE 3 (-NE)					
SQ 5-70 (-N)	6	MS 3 (-NE)	1.85	941	427	6.4	0.0113
SQE 5-70 (-N)		MSE 3 (-NE)					

¹ Including pump, motor, 1.5-metre cable and cable guard.

Electrical data, 1 × 200-240 V, 50/60 Hz

Pump type	Motor type	Input power, motor (P1) [kW]	Output power, motor (P2) [kW]	Required input power, pump [kW]	Rated current I _{1/1} [A]		Rated motor efficiency (η) [%]
					230 V	200 V	
SQ 5-15 (-N)	MS 3 (-NE)	0.53	0.70	0.33	2.3	2.7	70
SQE 5-15 (-N)	MSE 3 (-NE)						
SQ 5-25 (-N)	MS 3 (-NE)	0.92	0.70	0.63	3.9	4.7	70
SQE 5-25 (-N)	MSE 3 (-NE)						
SQ 5-35 (-N)	MS 3 (-NE)	1.29	1.15	0.92	5.6	6.5	70
SQE 5-35 (-N)	MSE 3 (-NE)						
SQ 5-50 (-N)	MS 3 (-NE)	1.70	1.55	1.22	7.3	8.7	74
SQE 5-50 (-N)	MSE 3 (-NE)						
SQ 5-60 (-N)	MS 3 (-NE)	2.08	1.55	1.51	8.9	10.6	74
SQE 5-60 (-N)	MSE 3 (-NE)						
SQ 5-70 (-N)	MS 3 (-NE)	2.43	1.85	1.81	10.7	12.0	74
SQE 5-70 (-N)	MSE 3 (-NE)						

SQ 7, SQ 7-N, SQE 7, SQE 7-N

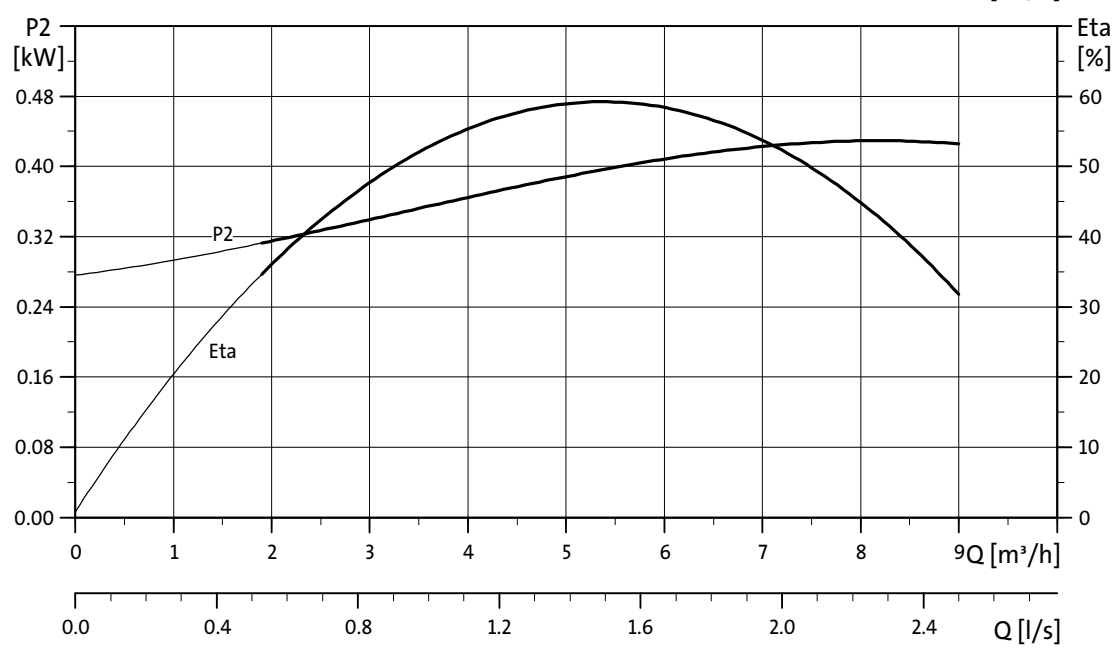
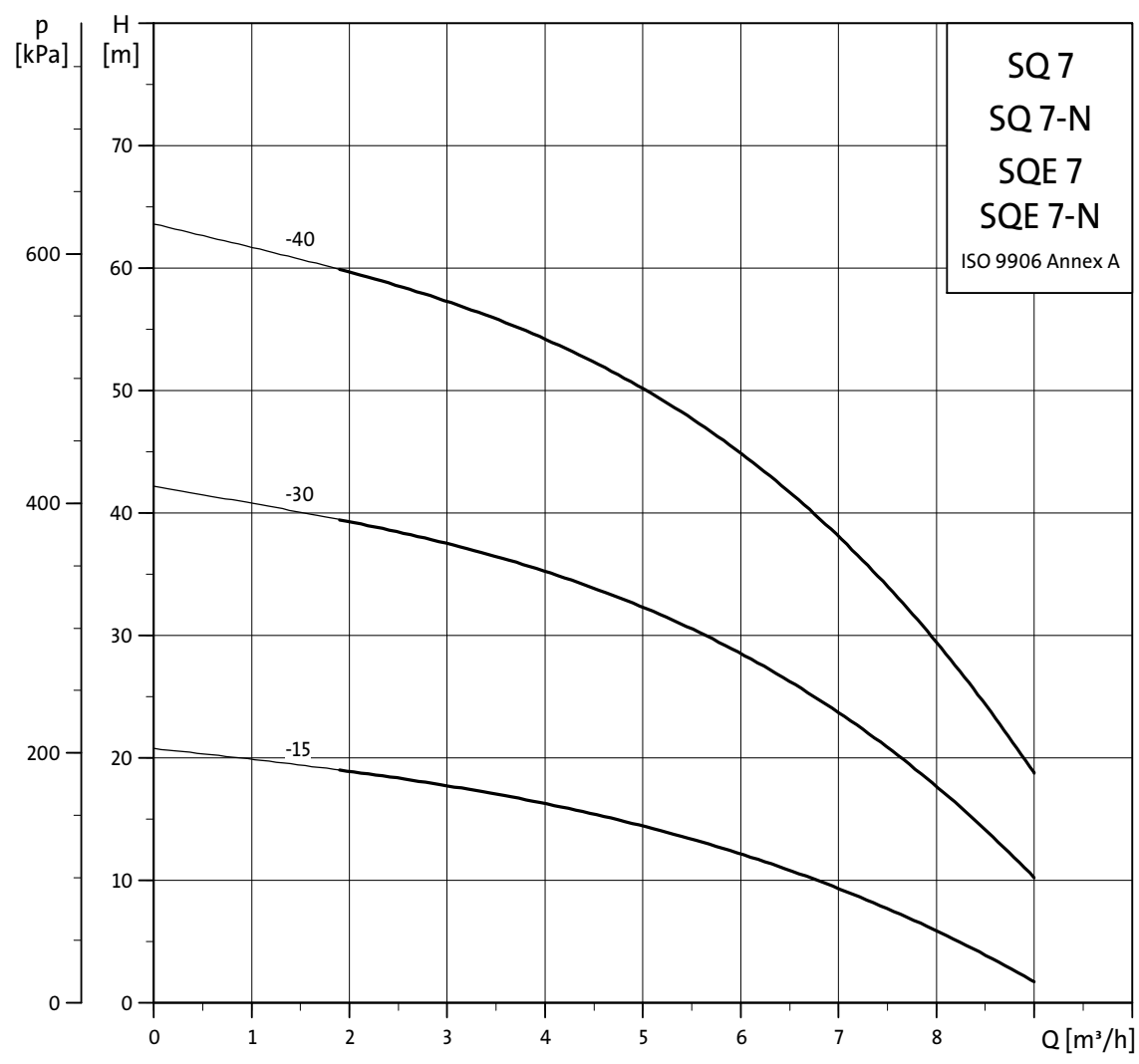

TM01 2696 4304

Dimensions and weights

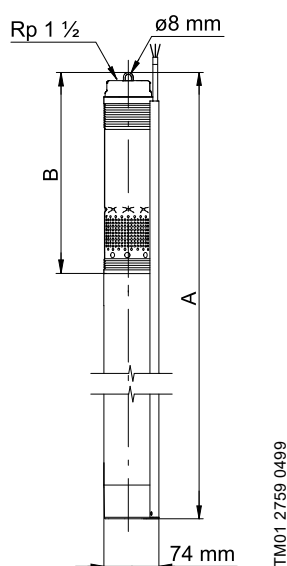

Pump type	Number of stages	Motor		Dimensions [mm]		Net weight [kg] ¹	Shipping volume [m ³] ¹
		Type	Output power (P2) [kW]	A	B		
SQ 7-15 (-N)	1	MS 3 (-NE)	0.7	743	265	4.7	0.0092
SQE 7-15 (-N)		MSE 3 (-NE)					
SQ 7-30 (-N)	2	MS 3 (-NE)	1.15	743	265	5.2	0.0092
SQE 7-30 (-N)		MSE 3 (-NE)					
SQ 7-40 (-N)	3	MS 3 (-NE)	1.55	860	346	6.1	0.0104
SQE 7-40 (-N)		MSE 3 (-NE)					

¹ Including pump, motor, 1.5-metre cable and cable guard.

Electrical data, 1 × 200-240 V, 50/60 Hz

Pump type	Input power, motor (P1) [kW]	Output power, motor (P2) [kW]	Required input power, pump [kW]	Rated current I _{1/1} [A]		Rated motor efficiency (η) [%]
				230 V	200 V	
SQ 7-15 (-N)	0.73	0.70	0.48	3.1	3.7	70
SQE 7-15 (-N)						
SQ 7-30 (-N)	1.26	1.15	0.90	5.5	6.4	73
SQE 7-30 (-N)						
SQ 7-40 (-N)	1.81	1.55	1.31	7.8	9.3	74
SQE 7-40 (-N)						

SQE 2-NE

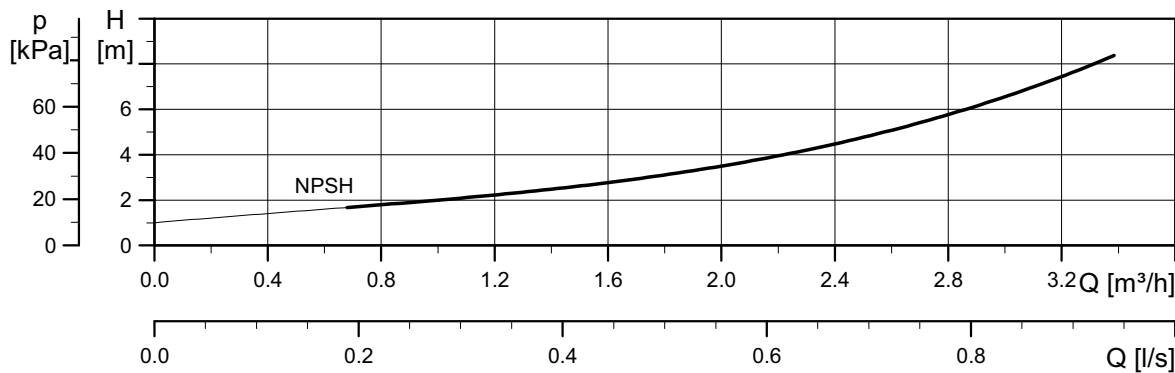
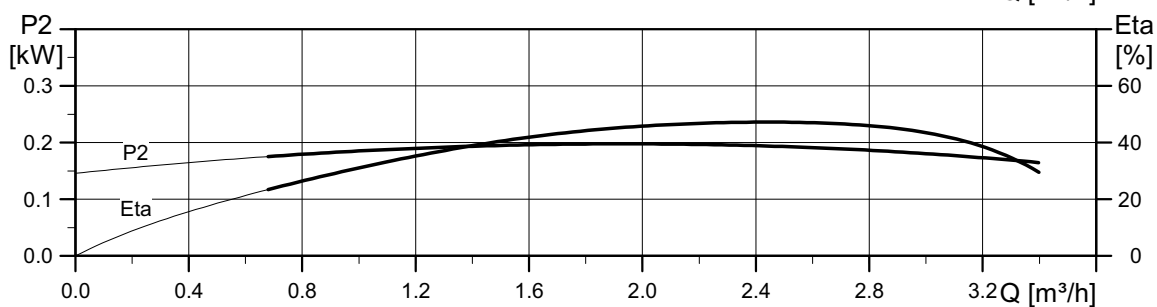
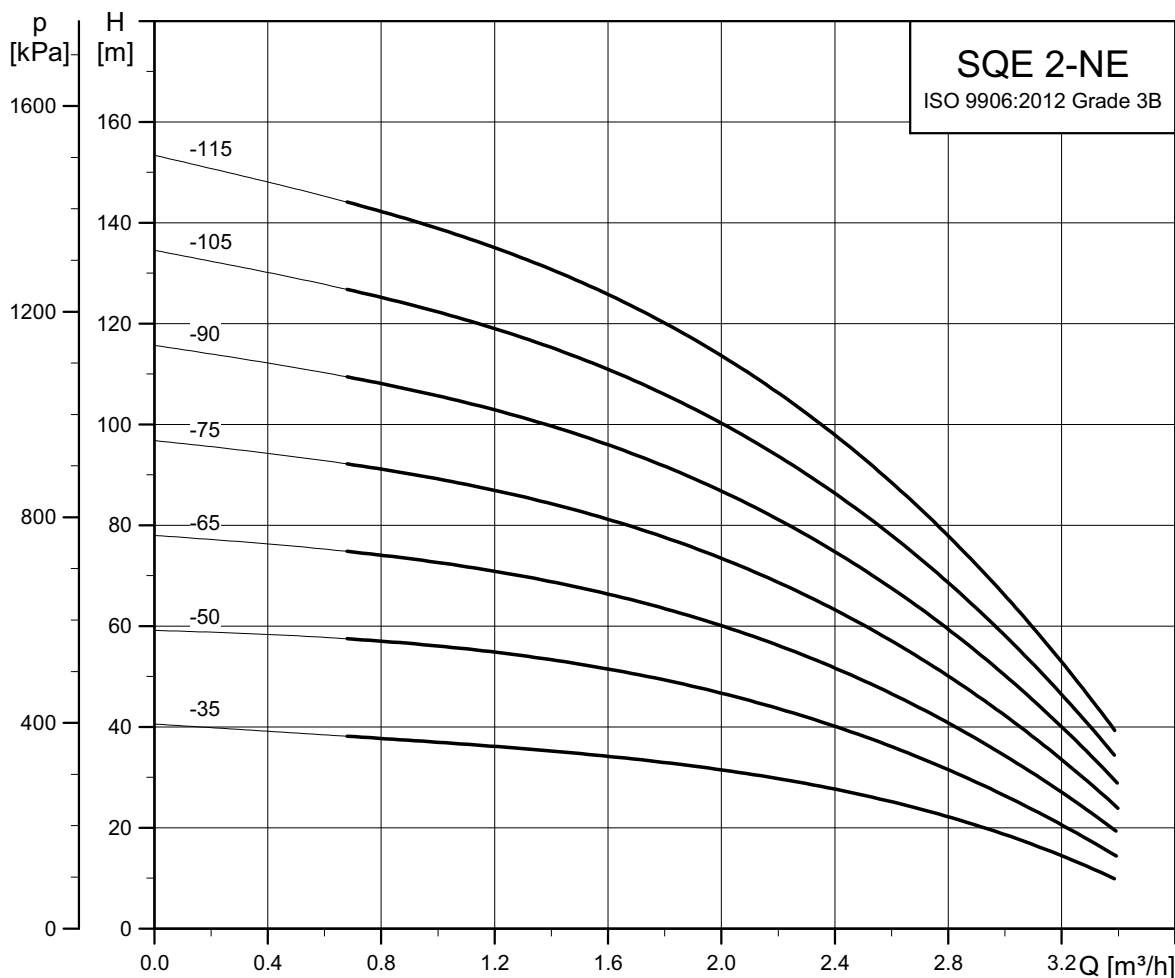

TM01 8600 0500

Dimensions and weights

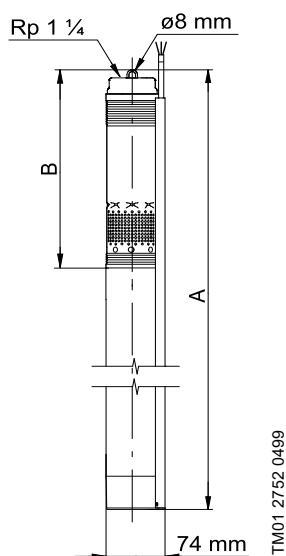

TM01 2752 0499

Pump type	Number of stages	Motor		Dimensions [mm]		Net weight [kg]	Shipping volume [m ³]
		Type	Output power (P2) [kW]	A	B		
SQE 2-35 NE	2	MSE 3-NE	0.1 - 0.7	744	268	4.7	0.0092
SQE 2-50 NE	3	MSE 3-NE	0.1 - 0.7	744	268	4.8	0.0092
SQE 2-65 NE	4	MSE 3-NE	0.7 - 1.15	771	295	5.4	0.0094
SQE 2-75 NE	5	MSE 3-NE	0.7 - 1.15	825	349	5.5	0.0100
SQE 2-90 NE	6	MSE 3-NE	1.1 - 1.55	825	349	6.2	0.0104
SQE 2-105 NE	7	MSE 3-NE	1.1 - 1.55	888	376	6.3	0.0107
SQE 2-115 NE	8	MSE 3-NE	1.1 - 1.55	942	430	6.4	0.0113

Electrical data, 1 × 200-240 V, 50/60 Hz

Pump type	Input power, motor (P1) [kW]	Output power, motor (P2) [kW]	Required input power, pump [kW]	Rated current I _{1/1} [A]		Rated motor efficiency (η) [%]
				230 V	200 V	
SQE 2-35 NE	0.69	0.70	0.46	3.0	3.5	70
SQE 2-50 NE	0.97	0.70	0.66	4.1	5.0	70
SQE 2-65 NE	1.22	1.15	0.87	5.3	6.2	73
SQE 2-75 NE	1.48	1.15	1.07	6.5	7.5	73
SQE 2-90 NE	1.77	1.55	1.28	7.6	9.1	74
SQE 2-105 NE	2.04	1.55	1.48	8.7	10.4	74
SQE 2-115 NE	2.30	1.55	1.69	9.9	11.8	74

SQE 5-NE

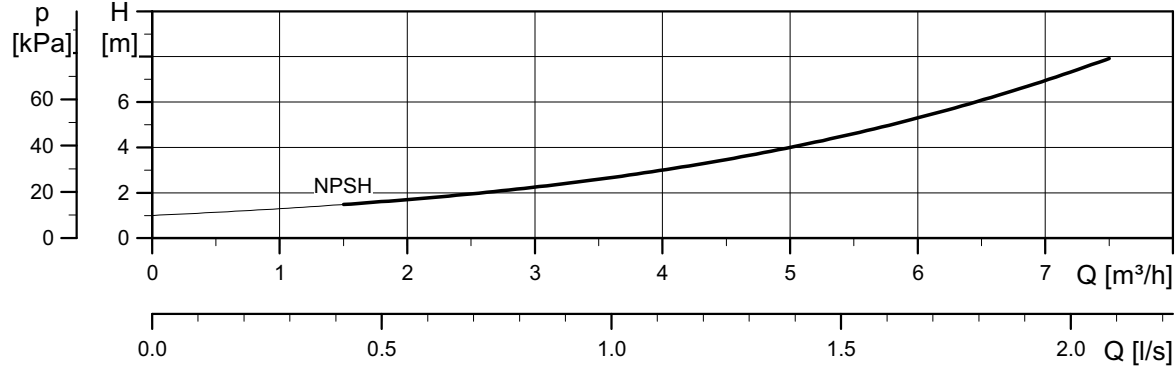
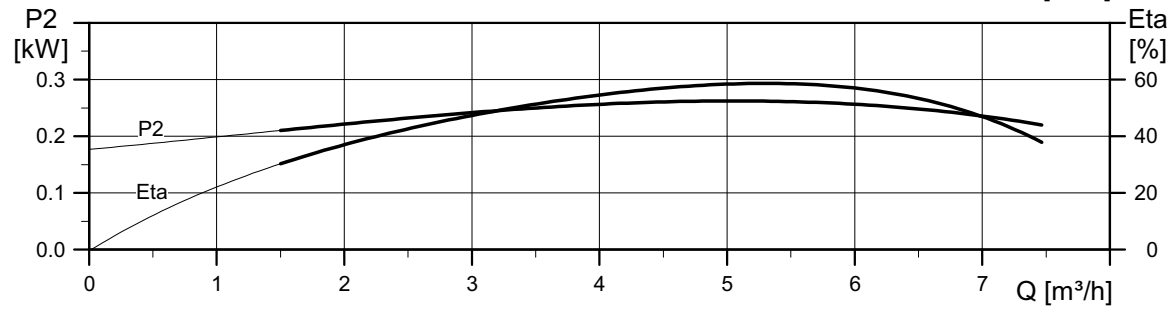
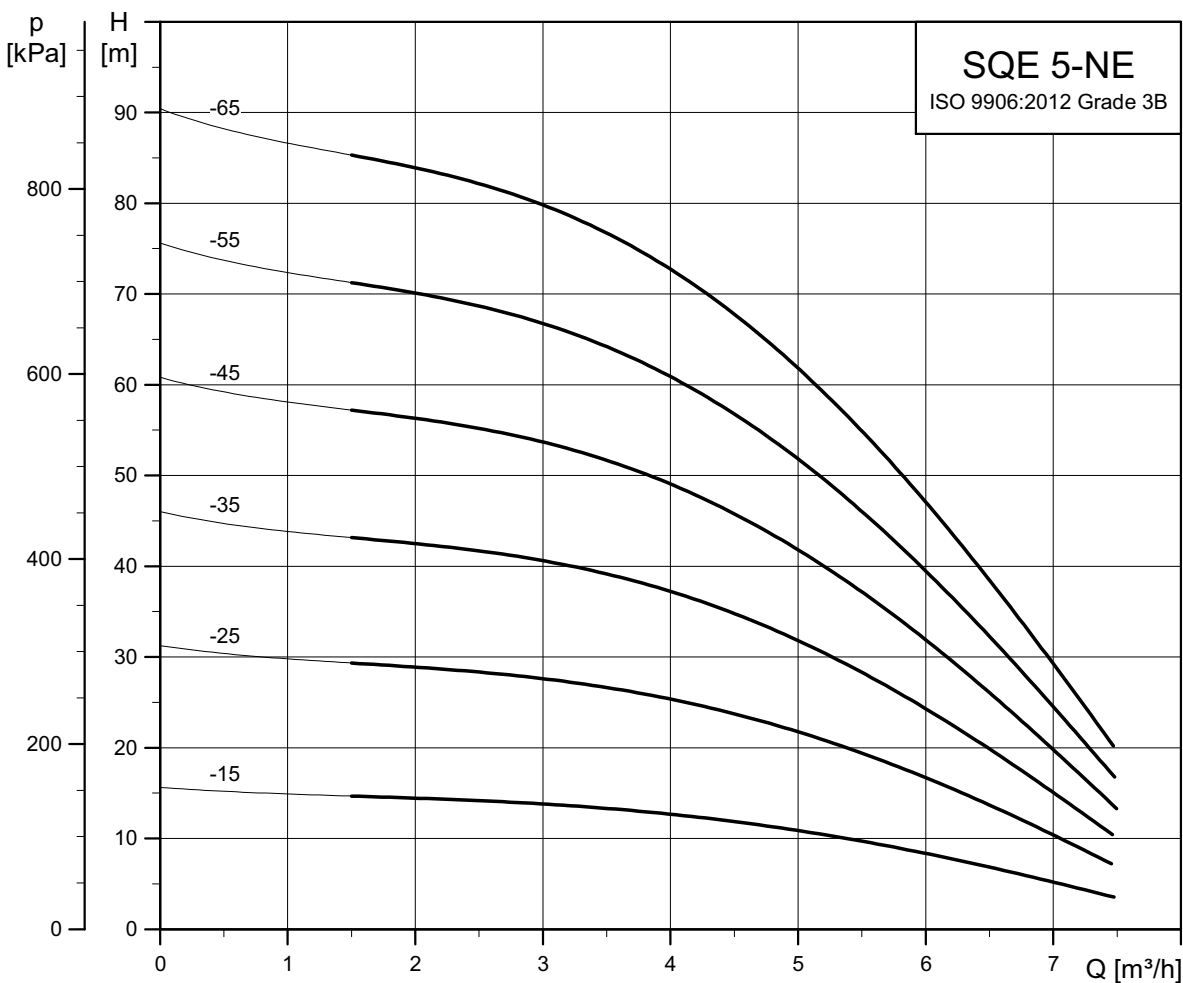

TM01 8602 0500

Dimensions and weights

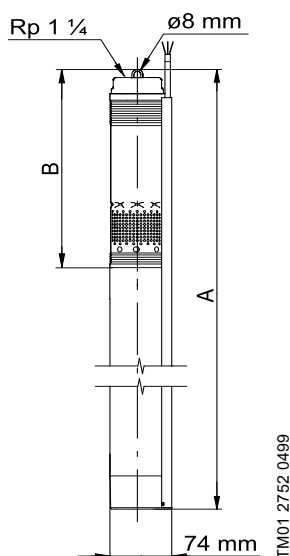

Pump type	Number of stages	Motor		Dimensions [mm]		Net weight [kg]	Shipping volume [m ³]
		Type	Output power (P2) [kW]	A	B		
SQE 5-15 NE	1	MSE 3-NE	0.1 - 0.7	744	268	4.7	0.0100
SQE 5-25 NE	2	MSE 3-NE	0.1 - 0.7	744	268	4.8	0.0100
SQE 5-35 NE	3	MSE 3-NE	0.7 - 1.15	825	295	5.5	0.0113
SQE 5-45 NE	4	MSE 3-NE	0.7 - 1.15	825	349	5.5	0.0113
SQE 5-55 NE	5	MSE 3-NE	1.1 - 1.55	942	430	6.4	0.0092
SQE 5-65 NE	6	MSE 3-NE	1.1 - 1.55	942	430	6.4	0.0092

Electrical data, 1 × 200-240 V, 50/60 Hz

Pump type	Input power, motor (P1) [kW]	Output power, motor (P2) [kW]	Required input power, pump [kW]	Rated current I _{1/1} [A]		Rated motor efficiency (η) [%]
				230 V	200 V	
SQE 5-15 NE	0.54	0.70	0.34	2.3	2.7	70
SQE 5-25 NE	0.89	0.70	0.61	3.8	4.6	70
SQE 5-35 NE	1.23	1.15	0.88	5.4	6.2	70
SQE 5-45 NE	1.58	1.15	1.15	6.9	8.7	73
SQE 5-55 NE	1.95	1.68	1.42	8.4	10.0	74
SQE 5-65 NE	2.30	1.68	1.69	9.9	11.8	74

7. Technical data

SQ and SQE pumps

Mains supply to pump	1 × 200-240 V - 10 % / + 6 %, 50/60 Hz, PE 1 × 100-115 V - 10 % / + 6 %, 50/60 Hz, PE
Starting	Soft starting
Stopping	Soft stopping when stopped by CU 300 or CU 301
Run-up time	Maximum 3 seconds No limitation to the number of starts/stops per hour
Motor protection	There is built-in motor protection against the following: <ul style="list-style-type: none"> • dry running • overvoltage and undervoltage (cuts out below 150 V and above 315 V) • overload • overtemperature.
Sound pressure level	The sound pressure level is lower than the limiting values stated in the EC Machinery Directive.
Radio noise	SQ and SQE pumps comply with the EMC Directive (2014/30/EU). Standards used: EN 55014-1: 2006 + A1:2009 + A2:2011, EN 55014-2: 1997 + A1:2001 + A2:2008, EN 61000-3-2: 2014 and EN 61000-3-3: 2013.
Reset function	SQE pumps can be reset via CU 300 or CU 301
Power factor	PF = 1
Operation via generator	We recommend that the generator output be equal to the motor input power (P1) plus 50 %, and at least (P1) plus 10 %.
Earth leakage circuit breaker	If the pump is connected to an electric installation where an earth leakage circuit breaker (ELCB) is used as an additional protection, the circuit breaker must trip when earth fault currents with pulsating DC content occur.
Pipe connection	SQ 1, SQ 2, SQ 3: Rp 1 1/4 SQ 5, SQ 7: Rp 1 1/2
Borehole diameter	Minimum 76 mm
Installation depth	The installation depth must be maximum 150 m below the static water table (15 bar). For horizontal installation, flow sleeve is recommended. The installation depth below dynamic water level (in either horizontal or vertical installation) must be 0.5 m.
NPSH	Minimum 8 m
Strainer	Holes in the suction strainer: Ø2.3 mm
Pumped liquids	SQ, SQE (EN 1.4301), SQ-N (EN 1.4401): pH 5 to 9. SQE-NE, see page 48. Sand content is allowed up to 50 g/m ³ .

CU 300 and CU 301 control units

Voltage	1 × 100-240 V - 10 % / + 6 %, 50/60 Hz, PE
Power consumption	5 W
Current consumption	Maximum 130 mA
Enclosure class	IP55
Ambient temperature	During operation: -30 °C to +50 °C During storage: -30 °C to +60 °C
Relative humidity	95 %
Pump cable	Maximum length between CU 300 or CU 301 and pump: 300 m
Backup fuse	Maximum 16 A
Radio noise	CU 300 and CU 301 comply with the EMC Directive (2014/30/EU). The standard used is EN 60730-1:2016.
Marking	CE
Load	Maximum 100 mA

Material specification, pump

SQ, SQ-N, SQE, SQE-N

Pos.	Component	Material	EN	AISI	EN	AISI
			SQ/ SQE	304	SQ-N/ SQE-N	316
1	Valve casing	Polyamide				
1a	Outlet chamber	Stainless steel	1.4301	304	1.4401	316
1d	O-ring	NBR rubber				
2	Valve cup	Polyamide				
3	Valve seat	NBR rubber				
4a	Empty chamber	Polyamide				
6	Top bearing	NBR rubber				
7	Neck ring	TPU/PBT				
7a	Lock ring	Stainless spring steel	1.4310	310	1.4404	316
7b	Neck ring retainer	Polyamide				
9b	Chamber top	Polyamide				
9c	Chamber bottom	Polyamide				
13	Impeller with tungsten carbide bearing	Polyamide				
14	Inlet interconnector	Polyamide				
14a	Ring	Stainless steel	1.4301	304	1.4401	316
16	Shaft with coupling	Stainless steel Sintered steel	1.4301	304	1.4401	316
18	Cable guard	Stainless steel	1.4301	304	1.4401	316
18a	Screws for cable guard	Stainless steel	1.4401	316	1.4401	316
30	Cone for pressure equalisation	Polyamide				
32	Guide vanes	Polyamide				
39	Spring	Stainless spring steel	1.4406	316 LN	1.4406	316 LN
55	Pump sleeve	Stainless steel	1.4301	304	1.4401	316
64	Priming screw	Polyamide				
70	Valve guide	Polyamide				
86	Lip seal ring	NBR rubber				
87	Cone for pressure equalisation complete	Polyamide/ NBR rubber				

Material specification, motor

SQ, SQ-N, SQE, SQE-N

Pos.	Component	Material	EN	AISI	EN	AISI
			MS 3/ MSE 3		MS 3-NE/ MSE 3-NE	
201	Stator	Stainless steel	1.4301	304	1.4401	316
220	Motor cable with plug	EPR				
222a	Filling plug	MS 3: silicone MSE 3-NE: silicone				
225	Top cover	1.4301 or 1.4401				
	Motor liquid	SML-3				

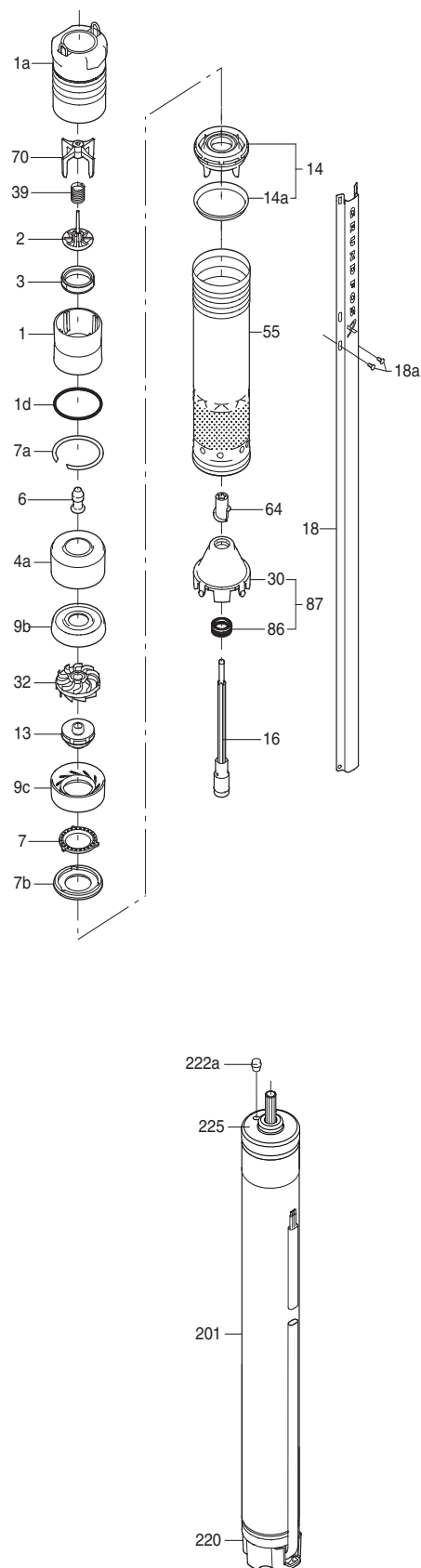

Fig. 29 Exploded view of pump and motor

TM01 2745 0706

Material specification, pump

SQE-NE

Pos.	Component	Material	EN	AISI
			MS 3-NE /MSE 3 -NE	
1	Valve casing	PVDF CN-F		
1a	Outlet chamber	Stainless steel	1.4401	316
1d	O-ring	FKM		
2	Valve cup	PVDF CN-F		
3	Valve seat	Silicone LSR		
4a	Empty chamber	PVDF CN-F		
6	Top bearing	FKM		
7	Neck ring	PVDF CN-F		
7a	Lock ring	Stainless steel	1.4404	316
7b	Neck ring retainer			
9b	Chamber top	PVDF CN-F		
9c	Chamber bottom	PVDF CN-F		
13	Impeller with tungsten carbide bearing	PVDF CN-F		
14	Inlet interconnector	PVDF CN-F		
14a	Ring	Stainless steel	1.4401	316
16	Shaft with coupling	Stainless steel Sintered steel	1.4401	316
18	Cable guard	Stainless steel	1.4401	316
18a	Screws for cable guard	Stainless steel	1.4401	316
30	Cone for pressure equalisation	PVDF CN-F		
32	Guide vanes	PVDF CN-F		
39	Spring	Stainless spring steel	1.4406	316LN
55	Pump sleeve	Stainless steel	1.4401	316
64	Priming screw	PPS 40 % GF		
70	Valve guide	PVDF CN-F		
86	Lip seal ring	FKM		
87	Cone for pressure equalisation complete	Polyamide/ NBR rubber		

Material specification, motor

SQE-NE

Pos.	Component	Material	EN	AISI
			MS 3-NE /MSE 3 -NE	
201	Stator	Stainless steel	1.4401	316
220	Motor cable with plug	EPR		
222a	Filling plug	MS 3-NE: silicone MSE 3-NE: silicone		
225	Top cover	1.4301 or 1.4401		
	Motor liquid	SML-3		

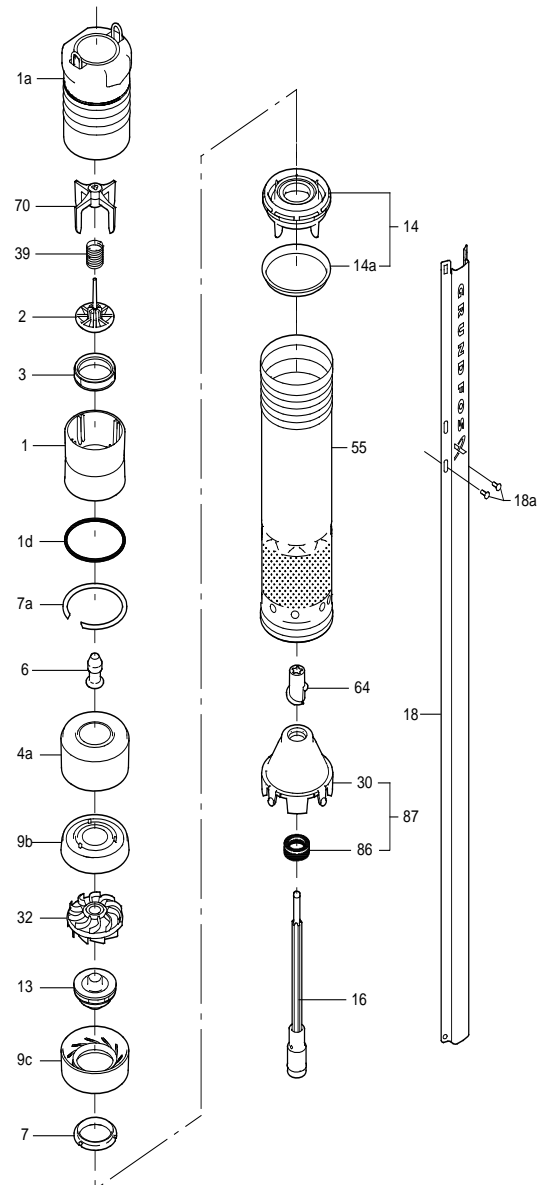

Fig. 30 Exploded view of pump and motor

TM01 2745 07/06

8. Resistance list, SQE-NE

A resistance list is a list of media that do not chemically attack the pump materials.

The tables on the following pages have been created on the basis of the following materials:

- stainless steel: EN 1.4401
- composite: PVDF.

The tables apply only to the SQE-NE range. See [Type key](#), page 7.

The media in the tables do not attack the SQE-NE pump materials chemically when the pump is submerged in them. However, precautions must be made to avoid, for example, explosion and increased power consumption.

The SQE-NE pumps are not generally approved as explosion-proof, therefore, local authorities and regulations must be consulted if in doubt whether the SQE-NE can be used.

If in doubt, contact Grundfos for further information.

A number of typical media are listed below. The list is intended as a guide only.

Pure saturated acids, not specified

	Medium	Chemical formula	Concentration [%]	Max. liquid temperature [°C]
Acids	Benzoic acid	C ₆ H ₅ COOH	100	20
	Boric acid	H ₃ BO ₃	30	40
	Chromic acid	H ₂ CrO ₄	20	-
	Citric acid	HOC(CH ₂ CO ₂ H) ₂ COOH	40	40
	Formic acid	HCOOH	100	-
	Hydrochloric acid	HCl	10	-
	Hydrogen fluoride	HF	1	20
	Lactic acid	CH ₃ CH(OH)COOH	100	-
	Linoleic acid	C ₁₇ H ₃₁ COOH	100	-
	Nitric acid	HNO ₃	10	-
	Oxalic acid	(COOH) ₂	15	40
	Phosphoric acid	H ₃ PO ₄	30	20
	Salicylic acid	C ₆ H ₄ (OH)COOH	40	40
	Sulfuric acid	H ₂ SO ₄	5	10

Neutral media

	Medium	Chemical formula	Concentration [%]	Max. liquid temperature [°C]	
	De-ionised water	-	H ₂ O	-	40

Alkaline media

	Medium	Chemical formula	Concentration [%]	Max. liquid temperature [°C]
Alkalis	Ammonia	NH ₃	25	-
	Ammonium hydroxide	NH ₄ OH	60	-
	Barium hydroxide	Ba(OH) ₂	10	40
	Calcium hydroxide	Ca(OH) ₂	10	-
	Calcium hypochlorite	Ca(ClO) ₂	10	-
	Potassium hydroxide	KOH	1	-
	Sodium hydroxide	NaOH	1	20
	Sodium hypochlorite	NaOCl	10	-

Salts in aqueous solutions

	Medium	Chemical formula	Concentration [%]	Max. liquid temperature [°C]
Acetate	Sodium acetate	CH ₃ COONa	1	20
Borate	Sodium tetra borate	Na ₂ B ₄ O ₇	1	40
Bromate	Bromate	BrO ₃ ⁻	1	40
Carbonates	Carbonate	CO ₃ ²⁻	1	40
	Potassium bicarbonate	KHCO ₃	10	40
	Potassium carbonate	K ₂ CO ₃	20	40
	Sodium carbonate	Na ₂ CO ₃	20	40
	Sodium hydrogen carbonate	NaHCO ₃	10	40
Chlorates	Sodium chlorate	NaClO ₃	20	-
	Sodium perchlorate	NaClO ₄	30	-
Chlorides	Aluminium chloride	AlCl ₃	0.1	-
	Ferric chloride	FeCl ₃	0.1	-
	Ferrous chloride	FeCl ₂	1	20
	Sodium chloride	NaCl	1000 ppm (0.1 %)	20
Chromates	Chromates	CrO ₄ ²⁻	1	40
	Potassium dichromate	K ₂ Cr ₂ O ₇	20	-
Hypochlorite	Hypochlorite	ClO ⁻	< 0.1	-
Iodide	Iodide	I ⁻	< 0.5	20
Nitrates	Nitrate	NO ₃ ⁻	1	40
	Ammonium nitrate	NH ₄ NO ₃	20	40
	Barium nitrate	Ba(NO ₃) ₂	10	40
	Silver nitrate	AgNO ₃	20	40
	Sodium nitrate	NaNO ₃	20	0
Nitrites	Nitrite	NO ₂ ⁻	1	40
	Sodium nitrite	NaNO ₂	20	40
Peroxides	Peroxide	O ₂ ²⁻	10	-
	Potassium permanganate	KMnO ₄	10	20
Phosphate	Sodium phosphate	Na ₃ PO ₄	1	40
Sulfates	Sodium metasilicate sulfate	Na ₂ SiO ₃	10	40
	Ammonium sulfate	(NH ₄) ₂ SO ₄	20	40
	Copper sulfate	CuSO ₄	20	40
	Ferric sulfate	Fe ₂ (SO ₄) ₃	10	40
	Ferrous sulfate	FeSO ₄	10	40
	Magnesium sulfate	MgSO ₄	20	40
	Sodium hydrogen sulfate	NaHSO ₄	10	40
	Sodium sulfate	Na ₂ SO ₄	10	40
	Sulfite	SO ₃ ²⁻	1	40
	Sulfites	Sodium hydrogen sulfite	NaHSO ₃	10
Sodium sulfite		Na ₂ SO ₃	20	20

Gasses, saturated solutions

	Medium	Chemical formula	Concentration	Max. liquid temperature [°C]
Gasses	Bromine	Br ₂	5 ppm	-
	Carbon dioxide	CO ₂	5 ppm	40
	Chlorine	Cl ₂	5 ppm	40C
	Hydrogen sulfide	H ₂ S	5 ppm	-
	Iodine	I ₂	5 ppm	-
	Ozone	O ₃	5 ppm	40
	Sulfur dioxide	SO ₂	5 ppm	40

Organic media

Homopolar media, oils

	Medium	Chemical formula	Concentration [%]	Max. liquid temperature [°C]
Mineral oils	ASTM1		100	40
	ASTM3		100	40
Silicone	Silicone oil		100	40
Vegetable/animal oils	Corn oil		100	20
	Olive oil		100	20
	Peanut oil		100	-
	Rape seed oil		100	20
	Soya bean oil		100	20

Homopolar media, fuels

	Medium	Chemical formula	Concentration [%]	Max. liquid temperature [°C]
Aromatic organic liquids	Benzene	C_6H_6	1	-
	Diphenyl	$C_6H_5C_6H_5$	1	25
	Toluene	$C_6H_5CH_3$	1	40
	Xylene	$C_6H_4(CH_3)_2$	1	40
Alicyclic organic liquids	Cyclohexane	C_6H_{12}	1	40
	Naphthalene	$C_{10}H_8$	1	-
Aliphatic organic liquids	Hexane	C_6H_{14}	1	40
	Octane	C_8H_{18}	1	40
	Pentane	C_5H_{12}	1	40
Mixtures	Diesel oil		1	40
	Jet fuel		1	-
	Motor oil		1	20
	Paraffin oil		1	20
	Petroleum		1	40
	Tar oil		1	-
	Turpentine		1	40

Polar media, chlorine-containing

	Medium	Chemical formula	Concentration [%]	Max. liquid temperature [°C]
Polar solutions	Chloroform	$CHCl_3$	1	25
	Methylene chloride	CH_2Cl_2	1	-
	Perchloroethylene	C_2Cl_4	1	25
	Tetrachloroethane	$C_2H_2Cl_4$	25	-
	Tetrachloroethylene	C_2Cl_4	25	-
	Trichlorethylene	C_2HCl_3	25	-

Polar media, oxygenous

	Medium	Chemical formula	Concentration [%]	Max. liquid temperature [°C]
Acids, low molecular	Acetic acid	CH ₃ COOH	100	-
	Formic acid	HCOOH	100	-
Alcohols	Butanol (butyl alcohol)	C ₄ H ₉ OH	100	40
	Ethanol (ethyl alcohol)	C ₂ H ₅ OH	100	-
	Methanol (methyl alcohol)	CH ₃ OH	100	-
	Phenol	C ₆ H ₅ OH	100	-
	Propanol	C ₃ H ₇ OH	100	20
Aldehydes	Benzaldehyde	C ₆ H ₅ CHO	100	-
	Formalin (formaldehyde)	CH ₂ O	30	-
Cyclic ether	Dioxane	C ₄ H ₈ O ₂	100	-
Esters	Ethyl acetate	CH ₃ COOC ₂ H ₅	100	-
	Isobutyl acetate	C ₆ H ₁₂ O ₂	100	-
Ethers	Cellosolve	C ₂ H ₅ OCH ₂ CH ₂ OH	100	-
	Diethyl ether	C ₂ H ₅ OC ₂ H ₅	100	-
	Methyl ethyl ether	C ₃ H ₈ O	100	-
Glycols	Ethylene glycol	HOCH ₂ CH ₂ OH	100	25
	Glycerine (glycerol)	OHCH ₂ CH(OH)CH ₂ OH	100	40
	Propylene glycol	CH ₃ CH(OH)CH ₂ OH	100	20
Ketones	Acetone	CH ₃ COCH ₃	100	-
	Acetophenone	C ₆ H ₅ COCH ₃	100	-
	Cyclohexanone	C ₆ H ₁₀ O	100	-
	MEK (methyl ethyl ketone)	C ₄ H ₈ O	100	-
	MIBK (methyl isobutyl ketone)	C ₆ H ₁₂ O	100	-

Polar media, P-containing

	Medium	Chemical formula	Concentration [%]	Max. liquid temperature [°C]
Phosphate ester	Skydrol 500		100	-
	Skydrol 7000		100	-
	Tributyl phosphate	(C ₄ H ₉) ₃ PO ₄	100	-

Polar media, N/containing

	Medium	Chemical formula	Concentration [%]	Max. liquid temperature [°C]
Additives for cooling lubricants	NACE A (water)			-
	NACE B (oil)			-
Amides	Acetamide	C ₂ H ₅ NO	100	-
	Formamide	CH ₃ NO	100	-
Amines	Aniline	C ₆ H ₅ NH ₂	100	20
	Dimethylamine	(CH ₃) ₂ NH	100	-
	Ethylamine	C ₂ H ₅ NH ₂	100	-
	Hydrazine	H ₂ NNH ₂	100	-
	tert-Butylamine	(CH ₃) ₃ CNH ₂	100	-
	Triethanolamine	(HOC ₂ H ₄) ₃ N	100	-
Cyclic organic liquid	Pyridine	C ₅ H ₅ N	100	-

Polar media, S-containing

	Medium	Chemical formula	Concentration [%]	Max. liquid temperature [°C]
Certain S-containing additives	Corrosion inhibitors			-
Extreme-pressure (EP) additives	Wear controlling additives			-

Aqueous solutions

	Medium	Chemical formula	Concentration [%]	Max. liquid temperature [°C]
Acetates	Copper acetate	$(\text{CH}_3\text{COO})_2\text{Cu}$	100	-
	Sodium acetate	CH_3COONa	100	-
Acids	Ascorbic acid	$\text{C}_6\text{H}_8\text{O}_6$	100	40
	Benzoic acid	$\text{C}_6\text{H}_5\text{COOH}$	100	20
	Citric acid	$\text{C}_6\text{H}_8\text{O}_7$	40	40
Formate	Sodium formate	HCOONa	100	-
Glycols	Glycol-based brake fluids			-
Salts of organic amines	Tetramethylammonium chloride	$\text{C}_4\text{H}_{12}\text{ClN}$	100	-

Wiring diagrams

Mains connection of pump via pressure switch

The pressure switch must be rated to the maximum amps of the specific pump size.

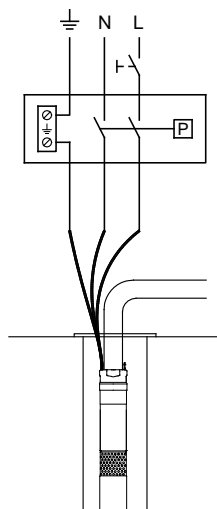

TM01 1480 4697

Fig. 31 Wiring diagram to main supply

Electrical connection of CU 301

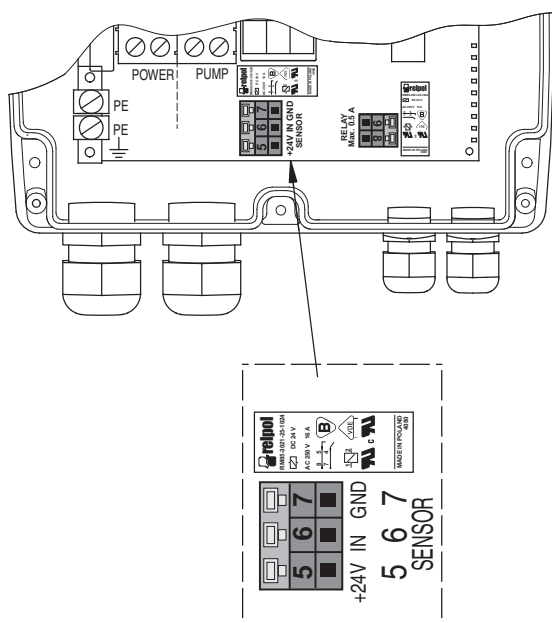

TM03 3430 0406

Fig. 32 Electrical connection of CU 301

Sensor

Voltage signal: DC 0-10 V/2-10 V, $R_i = 11 \text{ k}\Omega$
 Tolerance: $\pm 3 \%$ at maximum voltage signal.
 Screened cable recommended. Maximum cable length: 500 m.

Current signal: DC 0-20 mA/4-20 mA, $R_i = 500 \Omega$
 Tolerance: $\pm 3 \%$ at maximum current signal.
 Screened cable recommended. Maximum cable length: 500 m.

Product number for the pressure sensor, 4-20 mA, 0-6 bar: 96437851.

Operating relay

The operating relay is a normally open (NO) contact.
 The relay is activated when the pump is running.

- Maximum current: 0.5 A
- Maximum voltage: 230 VAC

Electrical connection of CU 300

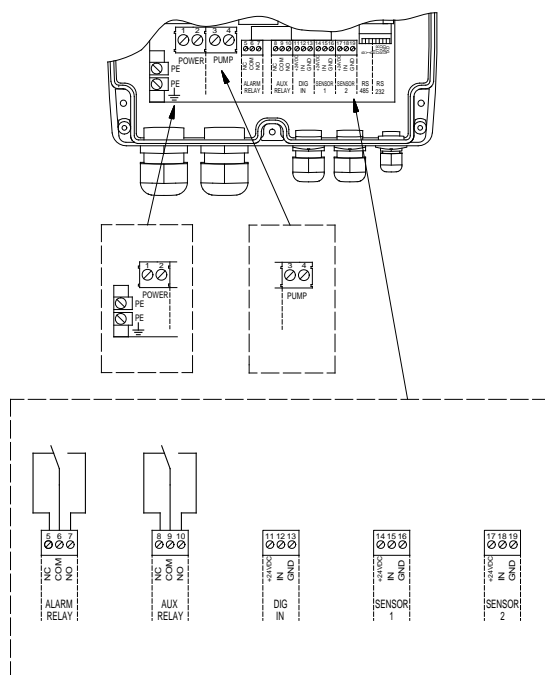

Alarm relay

Potential-free changeover contact.
Maximum contact load: AC 250 V, maximum current 1 A.
Minimum contact load: DC 5 V, 10 mA.

Auxiliary relay

Potential-free changeover contact.
Maximum contact load: Safety extra-low voltage to be used only.
Maximum current 1 A.
Minimum contact load: DC 5 V, 10 mA.

Digital input

External potential-free contact.
Logic "0": $U_{in} > 3.2$ V.
Logic "1": $U_{in} < 0.9$ V.

Sensor 1

Voltage signal: DC 0-10 V/2-10 V, $R_i = 11$ k Ω .
Tolerance: ± 3 % at maximum voltage signal.
Screened cable recommended. Maximum cable length: 500 m.

Current signal: DC 0-20 mA/4-20 mA, $R_i = 500$ Ω .
Tolerance: ± 3 % at maximum current signal.
Screened cable recommended. Maximum cable length: 500 m.

Sensor 2

Potentiometer: DC 0-24 V, 10 k Ω (via internal voltage supply).
Screened cable recommended. Maximum cable length: 100 m.

Voltage signal: DC 0-10 V/2-10 V, $R_i = 11$ k Ω .
Tolerance: ± 3 % at maximum voltage signal.
Screened cable recommended. Maximum cable length: 500 m.

Current signal: DC 0-20 mA/4-20 mA, $R_i = 500$ Ω .
Tolerance: ± 3 % at maximum current signal.
Screened cable recommended. Maximum cable length: 500 m.

TM01 3008 2898

Fig. 33 Electrical connection of CU 300

9. Accessories

CU 301



TM07 7843 4620

Product	Product number
CU 301 Elunit/Bar cpl. (Europe)	96436753
CU 301 Elunit/PSI cpl. w. sensor (USA)	96438895
CU 301 Elunit/Bar cpl. w. Sensor (Europe)	98594079
CU 301 Elunit/PSI cpl. (USA)	96436754
CU 301 Elunit/Bar cpl. (Japan)	96438896
CU301 Elunit/kPa cpl. (APREG)	96438897

Pressure sensor for CU 301

Product	Measuring range [bar]	Product number
Pressure sensor kit, including 2 m cable	0-6	405168

Constant-pressure package without the pump

Contents	Product number
<ul style="list-style-type: none"> CU 301 control unit Tank, 8 litres Pressure sensor, Pt 0-6 bar Pressure gauge, 10 bar, Ø63 Ball valve, 3/4" Cable clips, 20 pieces 	96524504

Note: The constant-pressure package can be used with all SQE pumps.

Constant-pressure packages with the pump

Contents	Pump type	Cable length [m]	Product number
	SQE 2-55	40	96524505
One constant-pressure package includes the following:	SQE 2-85	60	96524506
	SQE 2-115	80	96524507
	SQE 3-65	20	96524502
	SQE 3-65	40	96524501
	SQE 3-105	80	96524508
	SQE 5-50	40	96524509
	SQE 5-70	40	96524503

CU 300

Product	Product number
CU 300	96422775 (English)

Language-specific CU 300 versions are available on request.

Grundfos GO Remote MI 301

Grundfos GO Remote is used for wireless infrared or radio communication with the pumps.

MI 301 is a module with built-in infrared and radio communication. MI 301 must be used in conjunction with Android or iOS-based smart devices with a Bluetooth connection. MI 301 has rechargeable Li-ion battery and must be charged separately.



TM05 3890 1712

Fig. 34 MI 301

Product number: 98046408

SPP 1 potentiometer

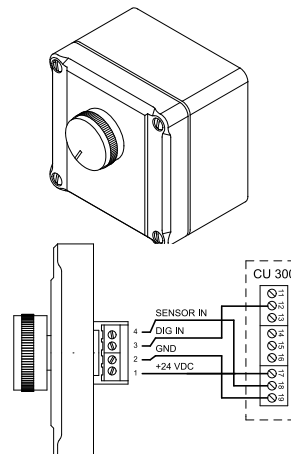

TM00 2604 4793 - TM01 3291 3798

Description	Version	Product number
External potentiometer with cabinet for wall mounting. Screened cables, 4-wire cable. Maximum cable length: 100 m.	Grundfos SPP 1 potentiometer. Enclosure class: IP55.	625468

Pressure Manager



TM04 0333 0508

Product	Voltage [V]	Maximum current [A]	Motor size (P2) [kW] / [hp]	Product number
PM 1 1.5 bar	230	6	0.7 / 0.5	96848693
PM 1 2.2 bar	230	6	0.7 / 0.5	96848722
PM 2	230	10	0.7 - 1.15 / 0.5 - 0.75	96848740

Product number: 98046408

Pressure gauge

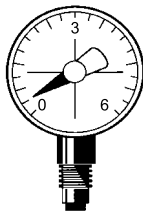

TM01 3092 3498

Measuring range [bar]	Connection	Diameter [mm]	Product number
0-6	G 1/4	50	ID3266
0-10	G 1/4	63	ID8048

Pressure tank

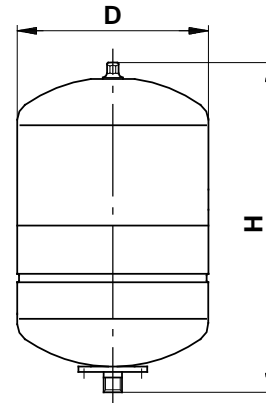

TM02 7934 4403

Duty range

Precharge pressure:	1.5 bar
Maximum operating pressure:	10 bar
Maximum liquid temperature:	+99 °C
Flange material:	Stainless steel

Description [litre]	Connection	D [mm]	H [mm]	Weight [kg]	Product number
8	G 3/4	202	303	2.3	96528335
18	G 3/4	279	367	4.6	96526322
24	G 1	289	447	5.1	96528339
33	G 1	289	584	6.7	96528340
60 ¹	G 1	397	557	11.0	96528341
80 ¹	G 1	397	755	16.0	96528342

¹ For installation on the floor. Fitted with 90° elbow.

Submersible drop cable



TM00 7882 2296

Description	Version	Nominal diameter [mm]	Product number
3-core cable including earth conductor (KTW-approved) ¹	3G 1.5 mm ² (round)	9.6 - 12.5	ID7946
	3G 2.5 mm ² (round)	11.5 - 14.5	ID7947
	3G 4.0 mm ² (round)	13.0 - 16.0	ID7948
	3G 6.0 mm ² (round)	14.5 - 20.0	RM4098
	3G × 1.5 mm ² (flat)	6.5 - 13.2	RM3952

¹ When ordering, state the length [m]

Cable termination kit, type KM

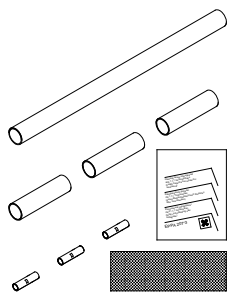

TM03 0181 4404

Description	Cross-section of leads [mm ²]	Product number
<p>The kit is for watertight shrink-joining of motor cable and submersible drop cable (round or flat cable).</p> <p>Enables the joining of:</p> <ul style="list-style-type: none"> • cables of equal size • cables of different size • cable leads with single leads. <p>The joint is ready for use after a few minutes and requires no long hardening time like resin joints.</p> <p>The joint cannot be separated.</p>	1.5 - 6.0	96021473

Cable clips



TM00 4179 1994

Description	Specification	Product number
<p>The clips are for fastening of cable and straining wire to the riser pipe.</p> <p>The clips must be fitted every 3 metres.</p> <p>One set is for approximately 45 m riser pipe.</p>	Length = 7.5 m 16 buttons	115016

Straining wire

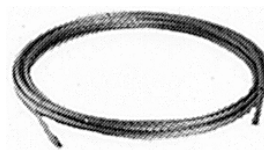

TM00 7897 2296

Description	Diameter [mm]	Product number
<p>The wire is stainless steel EN 1.4401. It retains the submersible pump.¹</p>	2	ID8957

¹ When ordering, state the length [m]

Wire clamp



TM00 7898 2296

Description	Material	Product number
Two clamps per loop	Stainless steel EN 1.4401	ID8960

Zinc anodes

Cathodic protection by means of zinc can be used for corrosion-protection of SQ/SQE pumps in chloride-containing liquids, such as brackish water and seawater.

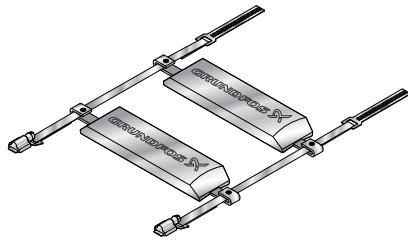

TM077621 4320

Description	Product number
Sacrificial anodes are placed on the outside of the pump and motor as protection against corrosion. The number of anodes required depends on the pump and motor in question. Typically 2 anodes are needed.	1 zinc anode: 99722879
Dimensions: Diameter when fitted: 125 mm. Minimum borehole diameter: 127 mm (5").	A set of fasteners: 99812400

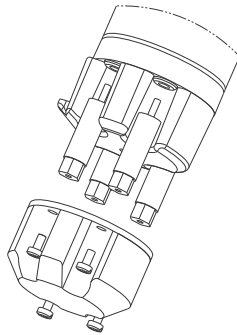

TM01 4430 0199

Description	Product number
Sacrificial anodes are placed on the bottom of the pump and motor as protection against corrosion. The number of anodes required depends on the pump and motor in question. The product number includes 1 zinc anode and 4 threaded rods.	99599098
Dimensions: The zinc anode adds 55 mm to the length of the pump. Minimum borehole diameter: 76 mm (3").	

Flow sleeve

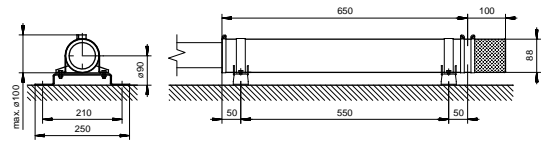

TM01 3292 3798

Description	Material	Product number
Flow sleeve including strainer and supporting bracket	Stainless steel EN 1.4301	98148594
Flow sleeve	Stainless steel EN 1.4301	97535677
Strainer	Stainless steel EN 1.4301	97943446
Supporting brackets	Stainless steel EN 1.4301	97512995

10. Order data

SQ, SQ-N, SQE, SQE-N

Complete unit, 1 × 200-240 V, 1.5 m cable

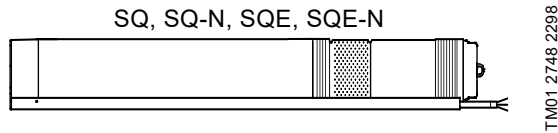

Complete unit: SQ 1, SQ 1-N, SQE 1, SQE 1-N

Pump type	Motor		Product number
	Type	Output power (P2) [kW]	
SQ 1-35	MS 3	0.70	96510178
SQ 1-35 N	MS 3-NE	0.70	96160370
SQE 1-35	MSE 3	0.70	96510071
SQE 1-35 N	MSE 3-NE	0.70	96160436
SQ 1-50	MS 3	0.70	96510179
SQ 1-50 N	MS 3-NE	0.70	96160371
SQE 1-50	MSE 3	0.70	96510141
SQE 1-50 N	MSE 3-NE	0.70	96160437
SQ 1-65	MS 3	0.70	96510190
SQ 1-65 N	MS 3-NE	0.70	96160372
SQE 1-65	MSE 3	0.70	96510142
SQE 1-65 N	MSE 3-NE	0.70	96160438
SQ 1-80	MS 3	1.15	96510191
SQ 1-80 N	MS 3-NE	1.15	96160373
SQE 1-80	MSE 3	1.15	96510143
SQE 1-80 N	MSE 3-NE	1.15	96160439
SQ 1-95	MS 3	1.15	96510192
SQ 1-95 N	MS 3-NE	1.15	96160374
SQE 1-95	MSE 3	1.15	96510144
SQE 1-95 N	MSE 3-NE	1.15	96160440
SQ 1-110	MS 3	1.15	96510193
SQ 1-110 N	MS 3-NE	1.15	96160375
SQE 1-110	MSE 3	1.15	96510145
SQE 1-110 N	MSE 3-NE	1.15	96160441
SQ 1-125	MS 3	1.55	96510194
SQ 1-125 N	MS 3-NE	1.55	96160376
SQE 1-125	MSE 3	1.55	96510146
SQE 1-125 N	MSE 3-NE	1.55	96160442
SQ 1-140	MS 3	1.55	96510195
SQ 1-140 N	MS 3-NE	1.55	96160377
SQE 1-140	MSE 3	1.55	96510147
SQE 1-140 N	MSE 3-NE	1.55	96160443
SQ 1-155	MS 3	1.85	96510196
SQ 1-155 N	MS 3-NE	1.85	96160378
SQE 1-155	MSE 3	1.85	96510148
SQE 1-155 N	MSE 3-NE	1.85	96160444

Complete unit: SQ 2, SQ 2-N, SQE 2, SQE 2-N

Pump type	Motor		Product number
	Type	Output power (P2) [kW]	
SQ 2-35	MS 3	0.70	96510198
SQ 2-35 N	MS 3-NE	0.70	96160379
SQE 2-35	MSE 3	0.70	96510150
SQE 2-35 N	MSE 3-NE	0.70	96160445
SQ 2-55	MS 3	0.70	96510199
SQ 2-55 N	MS 3-NE	0.70	96160380
SQE 2-55	MSE 3	0.70	96510151
SQE 2-55 N	MSE 3-NE	0.70	96160446
SQ 2-70	MS 3	1.15	96510200
SQ 2-70 N	MS 3-NE	1.15	96160381
SQE 2-70	MSE 3	1.15	96510152
SQE 2-70 N	MSE 3-NE	1.15	96160447
SQ 2-85	MS 3	1.15	96510201
SQ 2-85 N	MS 3-NE	1.15	96160382
SQE 2-85	MSE 3	1.15	96510153
SQE 2-85 N	MSE 3-NE	1.15	96160448
SQ 2-100	MS 3	1.55	96510202
SQ 2-100 N	MS 3-NE	1.55	96160383
SQE 2-100	MSE 3	1.55	96510154
SQE 2-100 N	MSE 3-NE	1.55	96160449
SQ 2-115	MS 3	1.85	96510203
SQ 2-115 N	MS 3-NE	1.85	96160384
SQE 2-115	MSE 3	1.85	96510155
SQE 2-115 N	MSE 3-NE	1.85	96160450

Complete unit: SQ 3, SQ 3-N, SQE 3, SQE 3-N

Pump type	Motor		Product number
	Type	Output power (P2) [kW]	
SQ 3-30	MS 3	0.70	96510204
SQ 3-30 N	MS 3-NE	0.70	96160386
SQE 3-30	MSE 3	0.70	96510156
SQE 3-30 N	MSE 3-NE	0.70	96160452
SQ 3-40	MS 3	0.70	96510205
SQ 3-40 N	MS 3-NE	0.70	96160387
SQE 3-40	MSE 3	0.70	96510157
SQE 3-40 N	MSE 3-NE	0.70	96160453
SQ 3-55	MS 3	1.15	96510206
SQ 3-55 N	MS 3-NE	1.15	96160388
SQE 3-55	MSE 3	1.15	96510158
SQE 3-55 N	MSE 3-NE	1.15	96160454
SQ 3-65	MS 3	1.15	96510207
SQ 3-65 N	MS 3-NE	1.15	96160389
SQE 3-65	MSE 3	1.15	96510159
SQE 3-65 N	MSE 3-NE	1.15	96160455
SQ 3-80	MS 3	1.55	96510208
SQ 3-80 N	MS 3-NE	1.55	96160390
SQE 3-80	MSE 3	1.55	96510160
SQE 3-80 N	MSE 3-NE	1.55	96160456
SQ 3-95	MS 3	1.55	96510209
SQ 3-95 N	MS 3-NE	1.55	96160391
SQE 3-95	MSE 3	1.55	96510161
SQE 3-95 N	MSE 3-NE	1.55	96160457
SQ 3-105	MS 3	1.85	96510210
SQ 3-105 N	MS 3-NE	1.85	96160392
SQE 3-105	MSE 3	1.85	96510162
SQE 3-105 N	MSE 3-NE	1.85	96160458

Complete unit: SQ 5, SQ 5-N, SQE 5, SQE 5-N

Pump type	Motor		Product number
	Type	Output power (P ₂) [kW]	
SQ 5-15	MS 3	0.70	96510211
SQ 5-15 N	MS 3-NE	0.70	96160393
SQE 5-15	MSE 3	0.70	96510163
SQE 5-15 N	MSE 3-NE	0.70	96160459
SQ 5-25	MS 3	0.70	96510212
SQ 5-25 N	MS 3-NE	0.70	96160394
SQE 5-25	MSE 3	0.70	96510164
SQE 5-25 N	MSE 3-NE	0.70	96160460
SQ 5-35	MS 3	1.15	96510213
SQ 5-35 N	MS 3-NE	1.15	96160395
SQE 5-35	MSE 3	1.15	96510165
SQE 5-35 N	MSE 3-NE	1.15	96160461
SQ 5-50	MS 3	1.68	96510214
SQ 5-50 N	MS 3-NE	1.55	96160396
SQE 5-50	MSE 3	1.55	96510166
SQE 5-50 N	MSE 3-NE	1.55	96160462
SQ 5-60	MS 3	1.55	96510215
SQ 5-60 N	MS 3-NE	1.55	96160397
SQE 5-60	MSE 3	1.55	96510167
SQE 5-60 N	MSE 3-NE	1.55	96160463
SQ 5-70	MS 3	1.85	96510217
SQ 5-70 N	MS 3-NE	1.85	96160398
SQE 5-70	MSE 3	1.85	96510168
SQE 5-70 N	MSE 3-NE	1.85	96160464

Complete unit: SQ 7, SQ 7-N, SQE 7, SQE 7-N

Pump type	Motor		Product number
	Type	Output power (P ₂) [kW]	
SQ 7-15	MS 3	0.70	96510218
SQ 7-15 N	MS 3-NE	0.70	96160399
SQE 7-15	MSE 3	0.70	96510169
SQE 7-15 N	MSE 3-NE	0.70	96160465
SQ 7-30	MS 3	1.15	96510219
SQ 7-30 N	MS 3-NE	1.15	96160400
SQE 7-30	MSE 3	1.15	96510170
SQE 7-30 N	MSE 3-NE	1.15	96160466
SQ 7-40	MS 3	1.55	96510220
SQ 7-40 N	MS 3-NE	1.55	96160401
SQE 7-40	MSE 3	1.55	96510171
SQE 7-40 N	MSE 3-NE	1.55	96160467

SQE-NE**Complete unit, 1 × 200-240 V**

The product numbers do not include the non-return valve, the cable and the plug which must be ordered separately. See table on page page 62.

SQE-NE

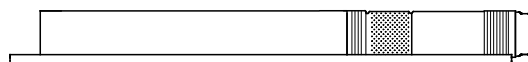

TM01 9173 1300

SQE 2-NE

Pump type	Motor		Product number
	Type	P ₂ [kW]	
SQE 2-35 NE	MSE 3-NE	0.70	97778403
SQE 2-55 NE	MSE 3-NE	0.70	97778404
SQE 2-65 NE	MSE 3-NE	1.15	97778405
SQE 2-75 NE	MSE 3-NE	1.15	97778406
SQE 2-90 NE	MSE 3-NE	1.55	97778407
SQE 2-105 NE	MSE 3-NE	1.55	97778408
SQE 2-115 NE	MSE 3-NE	1.55	97778409

SQE 5-NE

Pump type	Motor		Product number
	Type	P ₂ [kW]	
SQE 5-15 NE	MSE 3-NE	0.70	97778410
SQE 5-25 NE	MSE 3-NE	0.70	97778411
SQE 5-35 NE	MSE 3-NE	1.15	97778412
SQE 5-45 NE	MSE 3-NE	1.15	97778413
SQE 5-55 NE	MSE 3-NE	1.55	97778414
SQE 5-65 NE	MSE 3-NE	1.55	97778415

Submersible drop cables

The selection of drop cable dimension requires an evaluation of the voltage drop, the maximum motor current and the dimensioning current of the cable as a minimum. According to IEC 60364-5-52: 2009, 5 % is the maximum recommended voltage drop for cables up to 100 m. Where IEC does not apply, local regulations may require a different calculation. If the motor supply voltage drops below approximately 63 % of the nominal voltage, the motor will stop.

Maximum cable lengths

The maximum length for a given cable can be calculated by the following equation:

$$L_{Max} = \frac{U \times \Delta U}{I \times 2 \times 100 \times (PF \times \frac{\rho}{q})} [m]$$

L_{Max} = maximum cable length [m]

U = rated or nominal supply voltage [V]

ΔU = maximum recommended voltage drop [%]

I = maximum motor current [A]

The SQ and SQE product families use the MS3 and MSE3 motor family which has four different motor sizes (P2): 0,70 kW, 1,15 kW, 1,55 kW and 1,85 kW.

ρ = specific resistance: [$\Omega \text{ mm}^2/\text{m}$]

The specific resistance of the drop cables supplied by Grundfos for SQ and SQE is 0,02 [$\Omega \text{ mm}^2/\text{m}$].

q = cross-sectional area of the individual wires in the submersible drop cable [mm^2]

Note that the equation is valid only for SQ and SQE as it requires that the Power Factor (PF) of the motor unit equals 1.0. For SQ and SQE, the PF equals 1.0 due to the characteristics of the built-in inverter in the MS3 and MSE3 motors.

Calculation example

The following example calculates the maximum cable length of an SQ 2-55 MS3-motor with a P2 of 0.70 kW, using a drop cable with a wire cross-sectional area of 1.5 mm².

The following parameters are used:

Nominal supply voltage (U): 230 V

Maximum recommended voltage drop (ΔU): 5 %

Maximum motor current (I): 5.2 A for the MS3 motor with a P2 equal to 0.70 kW

Specific resistance of cable (ρ): 0.02 $\Omega \text{ mm}^2/\text{m}$

Cross-sectional area of the individual wires (q): 1.5 mm² cable

$$L_{Max} = \frac{240 \text{ V} \times 5 \%}{5.2 \text{ A} \times 2 \times 100 \times 1 \times \frac{0.02 \Omega \text{ mm}^2/\text{m}}{1.5 \text{ mm}^2}} = 150[m]$$

The table below shows the values for maximum cable length calculated for all MS3 motors in combination with the available sizes and lengths of drop cables.

P2 [kW]	I [A]	U [V]	ΔU [%]	Maximum cable length [m]			
				1.5 mm ²	2.5 mm ²	4 mm ²	6 mm ²
0.7	5.2	240	5	86	144	230	346
1.15	8.4	240	5	53	89	142	214
1.55	11.0	240	5	40	66	107	160
1.85	12.0	240	5	37	62	100	150

$\rho = 0.02 [\Omega \text{ mm}^2/\text{m}]$

SQ, SQ-N, SQE, SQE-N drop cables



Length [m]	Cross-section of leads			
	1.5 mm ²	2.5 mm ²	4 mm ²	6 mm ²
	Flat	Round	Round	Round
1.5	97778318	-	-	-
5	97778319	-	-	-
10	97778320	-	-	-
15	97778321	-	-	-
20	97778322	-	-	-
30	97778323	-	-	-
40	97778324	97778346	-	-
50	97778325	97778347	-	-
60	97778326	97778348	-	-
70	97778327	97778349	-	-
80	97778328	97778350	97778353	-
90	97778329	97778351	97778354	97778356
100	97778330	97778352	97778355	97778357

SQE-NE drop cables

Length		Product number
[m]	[ft]	All regions
1.5	5	97778280
7.5	25	97778281
15	50	97778282
23	75	97778283
30	100	97778284
38	125	97778285
45	150	97778286
53	175	97778287
61	200	97778288
68	225	97778289
76	250	97778290
84	275	97778291
91	300	97778292
99	325	97778293
106	350	97778294
114	375	97778295
122	400	97778296
130	425	97778297
137	450	97778298
145	475	97778299
152	500	97778300

SQE-NE drop cables have the following properties:

- 12 AWG (4 mm²) ETFE cable with end cover and socket
- leads: yellow and green (PE), black (phase), black (neutral).

Each product number in the tables above covers the following:

- one cable length with motor plug, packed
- 4 screws (M4) for fitting of plug
- 2 screws (M3 × 6) for fitting of cable guard to inlet strainer.

SQ and SQE including cable

Packages of SQ and SQE pumps including selected lengths of submersible drop cable are listed below.

The cable lengths in the table below are calculated according to the actual motor load of each specific pump size.

Pump type	Cable length (3 × 1.5 mm ²) [m]	Product number
SQ 1-65	30	96524421
SQ 1-80	30	96524428
SQ 1-80	50	96524429
SQ 1-140	70	96524442 ¹
SQ 2-35	15	96524423
SQ 2-55	10	96524430
SQ 2-55	15	96524431
SQ 2-55	30	96524432
SQ 2-55	60	96524433
SQ 2-70	30	96524434
SQ 2-70	60	96524436
SQ 2-70	80	96524435 ¹
SQ 2-85	40	96524443
SQ 2-85	80	96524444 ¹
SQ 3-30	30	96618723
SQ 3-40	15	96524426
SQ 3-40	30	96524427
SQ 3-40	30	96160577 ³
SQ 3-55	15	96524437
SQ 3-55	30	96524438
SQ 3-65	30	96524439
SQ 3-65	40	96524440
SQE 3-65	40	96524475
SQ 3-80	30	96524445
SQ 3-80	50	96524446
SQ 3-95	70	96524447 ¹
SQ 3-105	80	96524448 ²
SQ 5-35	15	96524441
SQ 5-35	30	96160956
SQE 5-35	30	96647657
SQ 5-50	15	96524449
SQ 5-50	30	96524450
SQ 5-60	30	96524451
SQ 5-70	30	96524452
SQ 7-40	15	96524453

¹ 3 × 2.5 mm²

² 3 × 4 mm²

³ Fitted with schuko plug.

11. Grundfos Product Center

Online search and sizing tool to help you make the right choice.

<http://product-selection.grundfos.com>



This drop-down menu enables you to set the search function to "Products" or "Literature".

"SIZING" enables you to size a pump based on entered data and selection choices.

"REPLACEMENT" enables you to find a replacement product. Search results will include information on the following:

- the lowest purchase price
- the lowest energy consumption
- the lowest total life cycle cost.

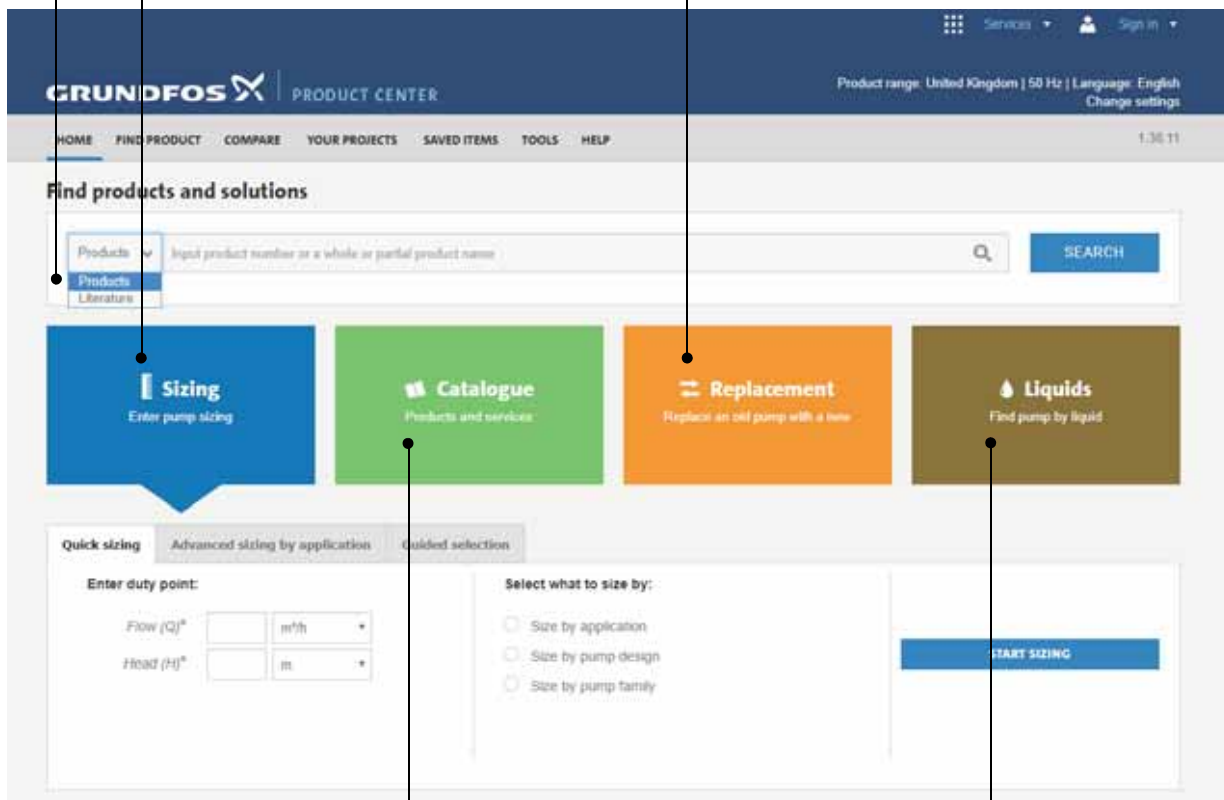

"CATALOGUE" gives you access to the Grundfos product catalogue.

"LIQUIDS" enables you to find pumps designed for aggressive, flammable or other special liquids.

All the information you need in one place

Performance curves, technical specifications, pictures, dimensional drawings, motor curves, wiring diagrams, spare parts, service kits, 3D drawings, documents, system parts. The Product Center displays any recent and saved items - including complete projects - right on the main page.

Downloads

On the product pages, you can download installation and operating instructions, data booklets, service instructions, etc. in PDF format.

V7141076 12.2020

ECM: 1300359