

SUBMERSIBLE EFFLUENT PUMP

Series: BPSTEP
0.5 & 1 HP / 3500 RPM
Discharge: 2"
Spherical solids handling: 3/4"



DISCHARGE

2" NPT, vertical.

LIQUID TEMPERATURE

104°F (40°C) continuous.

VOLUTE

Cast iron ASTM A-48 class 30.

MOTOR HOUSING

Cast iron ASTM A-48 class 30.

SEAL PLATE

Cast iron ASTM A-48 class 30.

IMPELLER

Design: single vane enclosed.

Material: polypropylene with stainless steel insert.

SHAFT

Stainless steel.

O-RINGS

Square shaped Buna-N.

PAINT

Air dry enamel, water based.

SEAL

Design: outboard single mechanical, oil filled chamber.

Material: carbon / ceramic / Buna-N, with stainless steel hardware.

HARDWARE

300 series stainless steel.

CORD ENTRY

30 ft of neoprene cord, sealed against moisture.

BEARINGS

Ball, single row, oil lubricated.

MOTOR

NEMA L, single phase, permanent split capacitor, 115 & 230 volts, 60 Hz, 3500 RPM, oil filled, class B insulation, with overload protection in motor.

OPTIONAL EQUIPMENT

Additional cord, seal material, impeller trims, slide rail coupling (SRC-2).

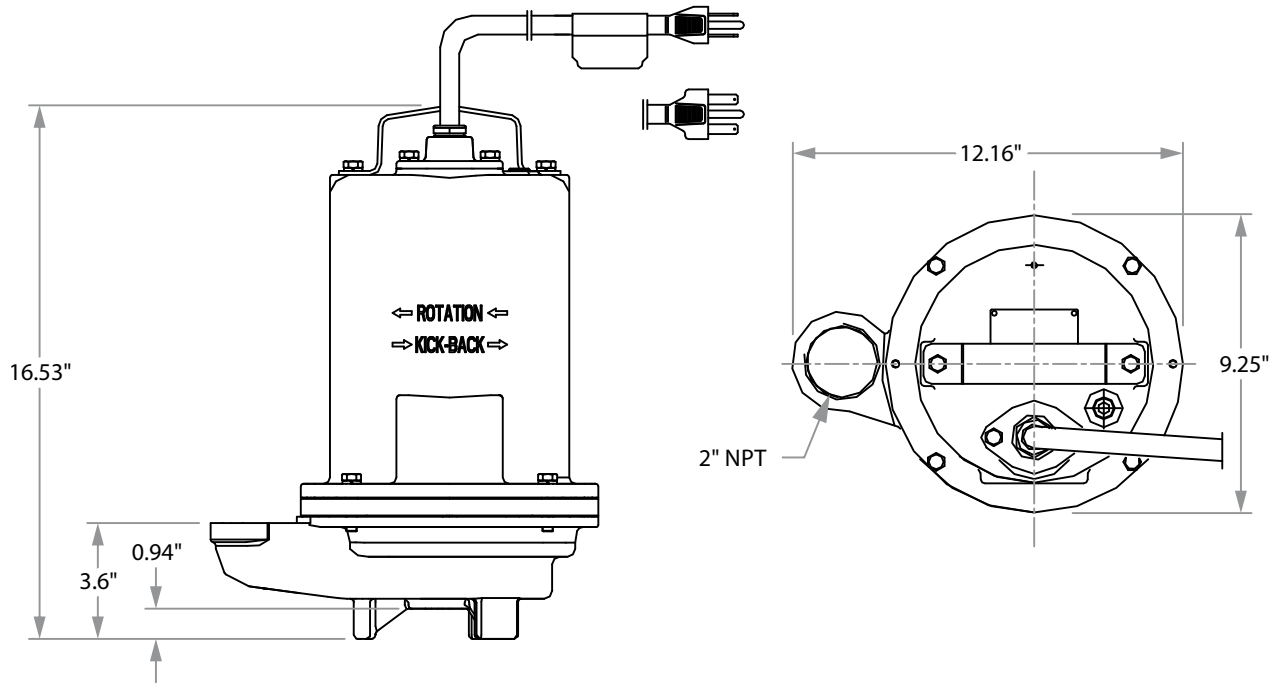

MODEL	PART No.	HP	VOLTS	PHASE	RPM (Nominal)	MAX AMPS	LOCKED ROTOR AMPS	NEMA CODE	CORD SIZE	CORD TYPE	WEIGHT (pounds)
BPSTEP512	62180203	0.5	115	1	3500	13.1	26.2	G	14/3	SOW	80
BPSTEP512A	62180204	0.5	115	1	3500	13.1	26.2	G	14/3	SOW	80
BPSTEP522	62180205	0.5	230	1	3500	5.6	13.2	E	14/3	SOW	80
BPSTEP1022	62180206	1	230	1	3500	9.1	23.5	f	14/3	SOW	80

A = Automatic Float Switch.

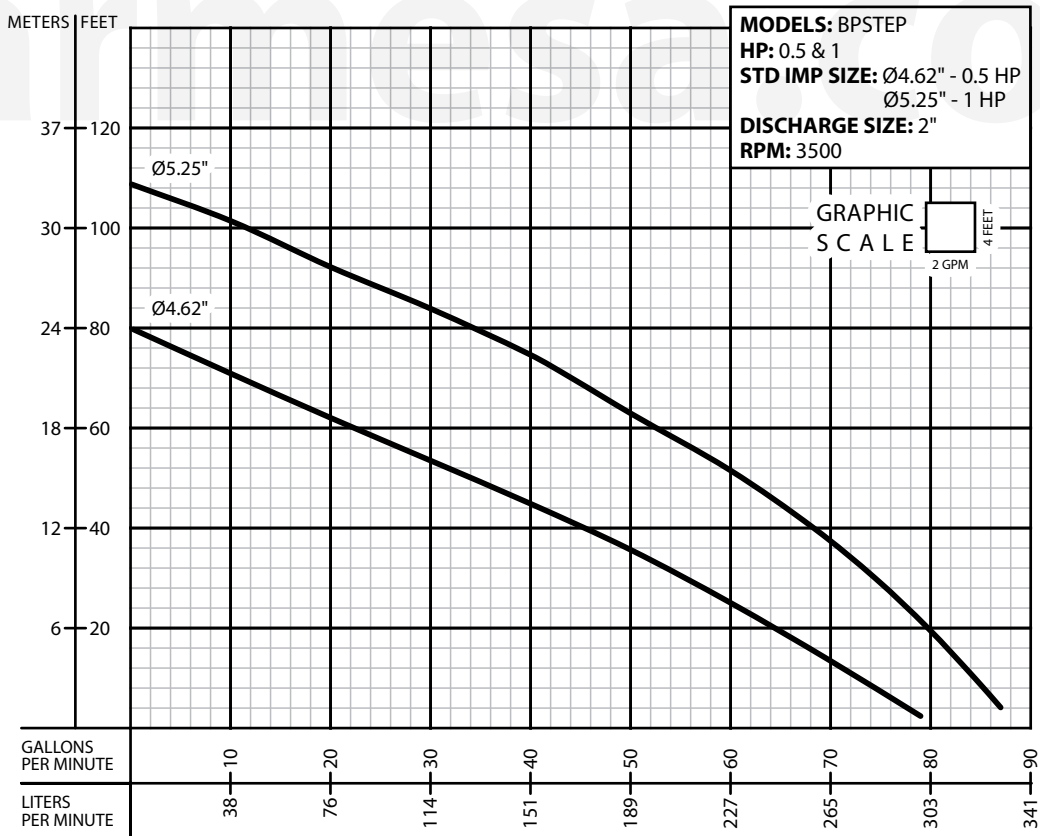

IMPORTANT!

1. Never use this pump to handle explosive liquids.
2. This pump is not approved to be used in swimming pools, recreational installations or any application where human contact may be common.
3. Pump may be operated "dry" for extended periods without damage to motor and/or seals.
4. Testing is performed with water specific gravity of 1.0 @ 68 °F (20 °C); other fluids may vary performance.