

INSTRUCTION MANUAL

IOMGWVICR01-EN

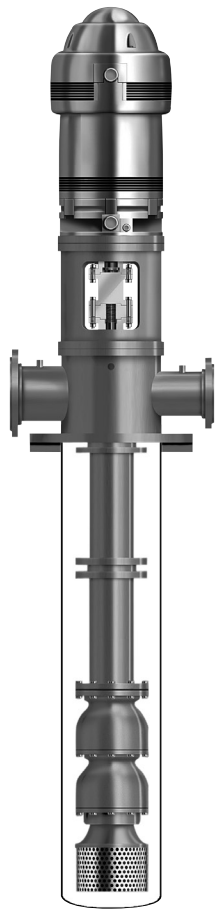

MODEL VIC

VERTICAL INDUSTRIAL TURBINE CAN PUMPS

INSTALLATION, OPERATION AND MAINTENANCE INSTRUCTIONS

Foreword

This manual provides instructions for the Installation, Operation, and Maintenance of the Goulds Water Technology Vertical Industrial Turbine Type Can Pumps. This manual covers a standard product. For special options, supplemental instructions are available. **This manual must be read and understood before installation and start-up.**

This instruction manual covers several different pump models. Most assembly, disassembly, and inspection procedures are the same for all the pumps. However, where there are differences, these differences will be noted within the manual. The design, materials, and workmanship incorporated in the construction of the Goulds Water Technology VIC pumps makes them capable of giving long, trouble-free service. The life and satisfactory service of any mechanical unit, however, is enhanced and extended by correct application, proper installation, periodic inspection, condition monitoring and careful maintenance. This instruction manual was prepared to assist operators in understanding the construction and the correct methods of installing, operating, and maintaining these pumps.

The information contained in this book is intended to assist operating personnel by providing information on the characteristics of the purchased equipment. It does not relieve the user of their responsibility of using accepted engineering practices in the installation, operation, and maintenance of this equipment.

Goulds Water Technology pumps shall not be liable for physical injury, damage, or delays caused by failure to observe the instructions for installation, operation, and maintenance contained in this manual.

Warranty is valid only when genuine Goulds Water Technology pumps parts are used.

Use of the equipment on a service other than stated in the order will nullify the warranty, unless written approval is obtained in advance from Goulds Pumps.

For information or questions not covered in this manual, contact Goulds Water Technology at (806) 743-5700.

THIS MANUAL EXPLAINS :

- Proper Installation
- Start-up Procedures
- Operation Procedures
- Routine Maintenance
- Pump Overhaul
- Trouble Shooting
- Ordering Spare or Repair Parts

Owner's Information

Pump Model Number: _____

Pump Serial Number: _____

Motor Model Number: _____

Motor Serial Number: _____

Dealer: _____

Dealer Telephone: _____

Purchase Date: _____

Installation Date: _____

Table of Contents

SUBJECT	PAGE
SECTION 1 – Safety	4
SECTION 2 – General Information	4
Introduction	4
Receiving and Checking	4
Materials and Equipment Required	5
Storage	5
General Description	6
SECTION 3 – Installation	9
Foundation / Piping	9
Pump Installation	10
Installing the Bowl Assembly	10
Installing the Column	11
Installing the Discharge Head	12
Installing the Stuffing Box	12
Installing the Mechanical Seal	13
Installing the Driver	14
Installing the Thrust Pot	14
SECTION 4 – Pump Start Up and Operation	20
SECTION 5 – Maintenance	21
Preventive Maintenance Schedule	21
Packing Adjustment and Replacement	21
Thrust Pot Lubrication and Maintenance	22
Seasonal Shutdown	22
Recommended Lubricants	23
Troubleshooting	24
SECTION 6 – Disassembly and Reassembly	26
Disassembly	26
Inspection and Reassemble	27
SECTION 7 – Repair Parts	29
Limited Warranty	30

Safety Instructions – SECTION 1

TO AVOID SERIOUS OR FATAL PERSONAL INJURY OR MAJOR PROPERTY DAMAGE, READ AND FOLLOW ALL SAFETY INSTRUCTIONS IN THE MANUAL AND ON THE PUMP.



This is a **SAFETY ALERT SYMBOL**. When you see this symbol on the pump or in the manual, look for one of the following signal words and be alert to the potential for personal injury or property damage.



DANGER Warns of hazards that **WILL** cause serious personal injury, death or major property damage.



WARNING Warns of hazards that **CAN** cause serious personal injury, death or major property damage.



CAUTION Warns of hazards that **CAN** cause personal injury or property damage.



If equipment is to be installed in a potentially explosive atmosphere and these procedures are not followed, personal injury or equipment damage from an explosion may result.

NOTICE: INDICATES SPECIAL INSTRUCTIONS WHICH ARE VERY IMPORTANT AND MUST BE FOLLOWED.

THIS MANUAL IS INTENDED TO ASSIST IN THE INSTALLATION AND OPERATION OF THIS UNIT. THOROUGHLY REVIEW ALL INSTRUCTIONS AND WARNINGS PRIOR TO PERFORMING ANY WORK ON THIS PUMP.

MAINTAIN ALL SAFETY DECALS.



! Install, ground and wire according to local and National Electrical Code Requirements.

! Install an all leg disconnect switch near the pump.

! Disconnect and lockout electrical power before installing or servicing the pump.

! Electrical supply must match motor's nameplate specifications. Incorrect voltage can cause fire, damage motor and void the warranty.

! Single phase pump motors are equipped with an automatic thermal protector, which opens the motor's electrical circuit when an overload condition exists. This can cause the pump to start unexpectedly.

General Precautions

! *Personal injuries will result if procedures outlined in this manual are not followed*

! *Electric supply MUST match pump's nameplate specifications. Incorrect voltage can cause fire, damage to motor and voids warranty.*

Safety Apparel:

- Insulated work gloves when handling hot sand collar.
- Heavy work gloves when handling parts with sharp

edges, especially impellers.

- Safety glasses (with side shields) for eye protection.
- Steel-toed shoes for foot protection when handling parts, heavy tools, etc.
- Other personal protective equipment to protect against hazardous/toxic fluid.

Maintenance Safety:

- Always lock out power prior to any procedure.
- Ensure pump is isolated from system and the pressure is relieved before disassembling the pump, removing plugs, or disconnecting the piping.
- Use proper lifting and supporting equipment to prevent serious injury or death.
- Observe all decontamination procedures.

General Information – SECTION 2

INTRODUCTION

NOTE: The information in this manual intends to be used as a guide only. If you are in doubt, consult your Goulds Water Technology representative for specific information about your pump.

The design, material, and workmanship incorporated in the construction of Goulds Water Technology VIC pumps makes them capable of giving long, trouble free service. The life and satisfactory service of any mechanical unit, however, is enhanced and extended by correct application, proper installation, periodic inspection and careful maintenance. This instruction manual was prepared to assist operators in understanding the construction and the correct methods of installing, operating and maintaining these pumps.

! *Rotating components of the pump assembly must be covered with a suitable rigid guard to prevent injury to personnel.*



Improper impeller adjustment could cause contact between the rotating and stationary parts, resulting in a spark and heat generation.

Study thoroughly Sections 1 through 6 and carefully follow the instructions for installing and operating. Section 5 contains answers to troubleshooting and maintenance questions. Keep this instruction manual handy for reference.

! *Goulds Water Technology will not be liable for any damages or delay caused by failure to comply with the provisions of this instruction manual.*

RECEIVING AND CHECKING

The pump should be carefully supported prior to unloading from the carrier. Handle all components carefully. Inspection for damage of the shipping crate should be made prior to unpacking the pump. After unpacking, visually inspect the pump and check the following:

1. Contents of the pump assembly against the packing list.
2. All components against damage.

3. All shafting for damage, should the crate be broken or show careless handling. All shafting must be checked for straightness.

Any shortages or damages should be immediately called to the attention of the local freight agent of the carrier by which the shipment arrived and proper notation made on the bill. This will prevent any controversy when a claim is made and facilitate prompt and satisfactory adjustment.

MATERIALS AND EQUIPMENT REQUIRED

The material and equipment necessary for installation of the pump will vary with the size of the pump and the type of installation.

The following list of standard tools and supplies is offered only as a guide.

BULK MATERIAL

- Anti-Galling lubricant (such as Dow Corning “MOLYKOTE”)
- Thread Compound
- Lubrication Oil
- Turbine Oil
- Grease

RIGGING EQUIPMENT

- Mobile power hoist, traveling crane or derrick.
- Drag line and blocks.
- Lifting Bail for Threaded Column.
- Elevator clamps, if unit is unassembled.
- Clevises – for use with eyebolts.
- Timbers – size, length and quantity to support long pump parts on the floor.
- I-Beams or timbers to support pump over installation.

HAND TOOLS

- Pipe wrenches
- Feeler gauges
- Machinist Level
- Set of mechanics tools including: files, wire brush, pliers, wire cutters and pocket knife.
- Clean rags
- Dial indicator to assist in motor and pump alignment.

OPTIONAL TOOLS TO FACILITATE PUMP ASSEMBLY AND DISASSEMBLY

- Taperlock driver to assist in bowl assembly and disassembly for pumps with taper lock impellers only.

STORAGE

Goulds Water Technology carefully preserves and protects its products for shipment. However, the effective life of the preservatives applied at the factory can vary from 3 to 18 months depending on the severity of the environment in which the equipment is stored. This section provides procedures for preparation prior to storage and maintenance during storage of Goulds Water Technology pumps. These procedures are necessary

to protect the precision parts of the pumps. Specific procedures for storing motors, gear-drivers, and engines, should be obtained from the equipment manufacturer. This section is intended to be of general assistance to users of Goulds Water Technology VIC pumps. It shall not modify, amend and/or otherwise alter the scope of Goulds Water Technology VIC pumps warranty responsibilities to the purchaser in any way whatsoever.

Storage Preparation

Goulds Water Technology VIC pumps require proper preparation for storage and, regular maintenance during storage. The pump shall be considered in storage when it has been delivered to the job site and is awaiting installation.

Preferably, the storage area shall be paved, well drained and free from flooding, and be indoors whenever possible.

Weatherproof coverings used for outdoor storage shall be flame resistant type sheeting or tarpaulins. They shall be placed so as to provide good drainage and air circulation and shall be tied down to protect from wind damage.

Storage area shall be maintained in a clean condition at all times.

Pumps and/or component parts shall be placed on skids, pallets, or shoring to permit good air circulation.

Pumps and/or component parts shall be sorted so as to permit ready access for inspection and/or maintenance without excessive handling.

Pumps and/or component parts stacked during storage shall be arranged so that the racks, containers, or crates bear full weight without distortion of pumps or parts. Identification markings must be readily visible. Any cover removed for internal access shall be replaced immediately.

Pump and bowl assembly shafting shall be rotated counter clockwise, as a minimum, once a month. Shaft shall not be left in the same previous position, nor in the extreme raised or lowered lateral position. Shaft should rotate freely.

NOTE: For further information on these procedures contact your Goulds Water Technology representative.

Recommended Storage Procedures

Controlled storage facilities should be maintained at an even temperature 10° F (6° C) or more above the dew point with relative humidity less than 50% and little or no dust. (If these requirements can not be met the pump is to be considered in uncontrolled storage.)

For uncontrolled storage periods of 6 months or less, the pump is to be inspected periodically to insure that all preservatives are intact.

All pipe threads and flanged pipe covers are to be sealed with tape.

The pump must not be stored closer than six inches (15 cm) from the ground.

Uncontrolled Long Term Storage Preparations

When applicable to the pump, storage periods over six months require the preceding storage procedure and storage preparation plus the following:

Inspect the lube oil and seal flush piping and either fill the piping with rust preventative oil, or re-coat the piping periodically to prevent corrosion.

Place 10 pounds (4.5 kg) of moisture absorbing desiccant or 5 pounds (2.3 kg) of vapor phase inhibitor crystals near the center of the pump. If the pump is assembled, place an additional one pound (0.5 kg) in the discharge nozzle securely fastened to the discharge elbow.

Install a moisture indicator near the perimeter of the pump. Cover the pump with 6 mil (0.15 mm) minimum thickness black polyethylene or equal and seal it with tape. Provide a small ventilation hole approximately ½ inch (12 mm) diameter.

Provide a roof or shed shelter to protect from direct exposure to the elements.

GENERAL DESCRIPTION

The model VIC pump is a vertical industrial turbine type pump installed in a can (barrel), and is designed to meet wide ranges of service with maximum dependability. See Figure 1 or Figure 2 for some typical VIC pump.

Drivers

When mechanical seals are required, the most common type of drivers supplied are solid vertical shaft motors with adjustable spacer type couplings. When packed stuffing boxes are used with open line shaft pumps, hollow shaft motors or right angle gear drives, are often used with a separate head shaft through the driver and connected to the pump by a threaded coupling.

Discharge Head

The discharge head is either a cast iron head or a fabricated head. Ports are provided for connecting the pressure gauge, stuffing box or mechanical seal bypass return and lubricator connections. The driver support portion of the discharge head is designed with large windows for easy stuffing box or mechanical seal adjustment. The windows are covered with coupling guards for safe operation.

Column

Threaded or flanged column construction provides positive shaft and bearing alignment and ease of assembly and disassembly. The line-shaft is supported within the column by using bearing retainers in the column assembly. The retainers are usually integrally fabricated in the column pipes. Bearings are spaced to provide vibration free operation below the shaft first critical speed in order to insure long bearing life and reduced shaft wear.

Bowl Assembly

The bowls are generally of flanged construction for accurate alignment and ease of assembly and disassembly. Impellers may be either open or enclosed depending on the design requirements. They are fastened to the pump shaft by taperlocks. For temperatures over 140°F (60°C) and in the larger size bowls (over 18"), impellers are keyed to the shaft. A special first stage low NPSH impeller may be provided in certain application.

Thrust Pot

A thrust pot is utilized when the driver is not designed to carry the pump thrust.

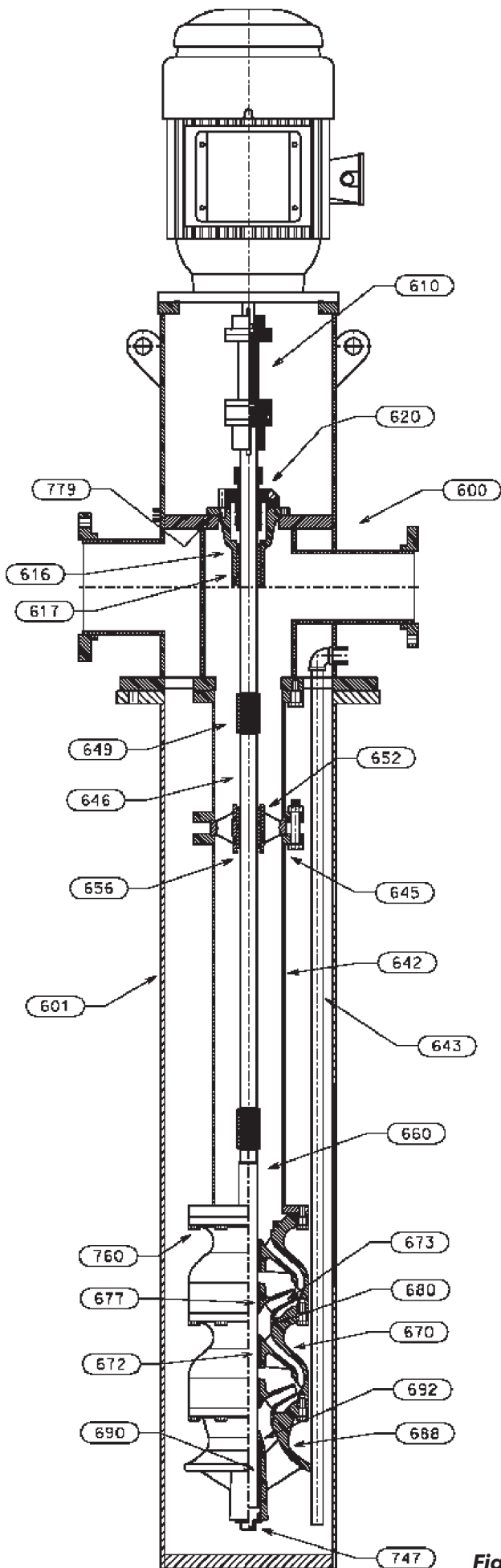

DISCHARGE HEAD ASSEMBLY

ITEM	DESCRIPTION
600	DISCHARGE HEAD
610	COUPLING ASSEMBLY
617	SEAL HOUSING BEARING
616	SEAL HOUSING
779	SEAL HOUSING GASKET
620	MECHANICAL SEAL

COLUMN ASSEMBLY

642	COLUMN PIPE
645	COLUMN BOLTING
646	LINESHAFT
649	LINESHAFT COUPLING
652	BEARING RETAINER
656	LINESHAFT BEARING
643	CLEAN-OUT PIPE (OPTIONAL)
601	BARREL

BOWL ASSEMBLY

660	PUMP SHAFT
670	INTERMEDIATE BOWL
672	INTER. BOWL BEARING
673	IMPELLER
677	TAPERLOCK
680	WEAR RING (OPTIONAL)
760	HEX BOLT
692	SAND COLLAR
688	SUCTION BOWL/BELL
690	SUCTION BEARING
747	PLUG

Figure 1 VIC Pump with Solid Shaft Motor, Fabricated T-Head, Mechanical Seal and Flanged Column

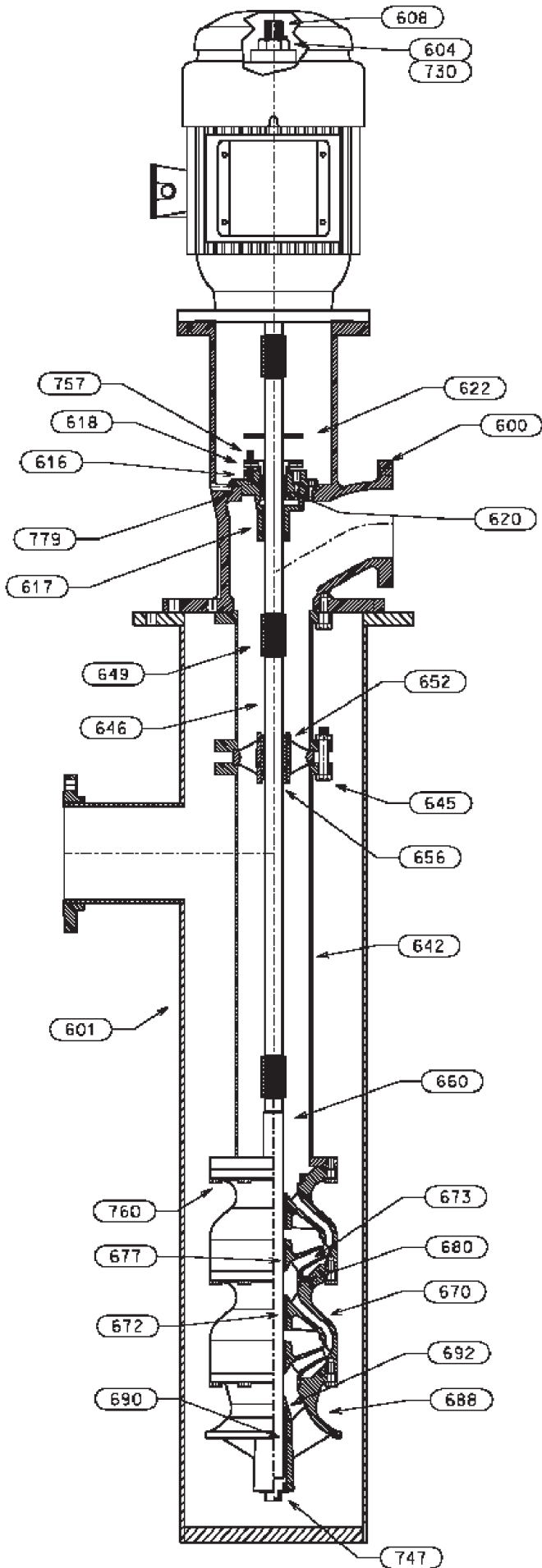

DISCHARGE HEAD ASSEMBLY

ITEM	DESCRIPTION
600	DISCHARGE HEAD
604	ADJUSTING NUT
730	GIB KEY
608	HEAD SHAFT
616	STUFFING BOX
617	STUFFING BOX BEARING
618	SPLIT GLAND
620	PACKING
622	SLINGER
757	GLAND ADJUSTING SCREW
779	STUFFING BOX GASKET

COLUMN ASSEMBLY

642	COLUMN PIPE (FLG)
645	COLUMN BOLTING
646	LINESHAFT
652	BEARING RETAINER
656	LINESHAFT BEARING
649	LINESHAFT COUPLING
601	BARREL

BOWL ASSEMBLY

660	BOWL SHAFT
670	INTERMEDIATE BOWL
672	INTER. BOWL BEARING
673	IMPELLER
677	TAPERLOCK
680	WEAR RING (OPTIONAL)
760	HEX BOLT
692	SAND COLLAR
688	SUCTION BOWL/BELL
690	SUCTION BEARING
747	PLUG

Figure 2 VIC Pump with Cast L-Head, VHS Motor, Packed stuffing Box and flanged column

Installation – SECTION 3



When pumping unit is installed in a potentially explosive environment, the instruction after the Ex symbol must be followed. Personal injury and/or equipment damage may occur if these instructions are not followed. If there is any question regarding these requirements or equipment is to be modified, please contact a Goulds Water Technology representative before proceeding.

FOUNDATION AND PIPING

SUB BASE (SOLE PLATE) OR BARREL FLANGE INSPECTION

Sub base and sole plate are terms in common use to describe a general class of solid steel plates mounted in grout (or bolted to steel structures) at the pump-foundation interface.

1. Remove the sub base from the pump discharge head or barrel flange, when shipped assembled.
2. Completely clean the underside of the sub base. It is sometimes necessary to coat the underside of the sub base with an epoxy primer. (This is available as an option.)
3. Remove the rust preventative solution from the machined topside with an appropriate solution.

SITE WITH CONCRETE FOUNDATION

1. A pump should have adequate space for operation, maintenance, and inspection.
2. Sub base mounted pumps are normally grouted on a concrete foundation, which has been poured on a solid footing. The foundation must be able to absorb any vibration and to form a permanent, rigid support for the pumping unit.
3. The foundation must be of adequate strength to support the complete weight of the pump, plus the weight of the liquid passing through it. A typical installation will have bolts with a pipe sleeve $2\frac{1}{2}$ times the bolt diameter embedded in the concrete.

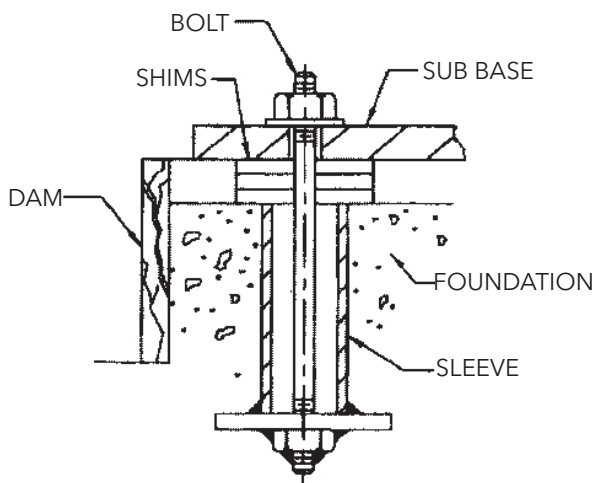

Figure 3

Bolts should be sized and located in accordance with the dimensions given on the Certified Pump Outline Drawing, if provided. The pipe sleeve allows movement for the final positioning of the foundation bolts to conform to the holes in the sub base flange. See Figure 3.



All equipment being installed must be properly grounded to prevent unexpected static electrical discharge. If not, a static electric discharge may occur when the pump is drained and disassembled for maintenance purpose.

4. Remove water and/or debris from anchor bolt holes/sleeves prior to grouting. If the sleeve type bolts are being used, fill the sleeves with packing or rags to prevent grout from entering.
5. Carefully lower the sub base onto the foundation bolts. Hand tighten the nuts.
6. Leveling the sub base may be done by several methods. Two common methods are:
 - A. Using leveling wedges. This is shown in Figure 4.
 - B. Leveling nuts on the anchor bolts.

Regardless of the method, a machinist level must be used for leveling.

NOTE: When using a machinist level, it is important that the surface being leveled is free of all contaminants, such as dust, to ensure an accurate reading.

7. Level the sub base in two directions at 90° on the machined surface. The levelness tolerance is 0.005 inches per foot for commercial, and 0.001 inches per foot for API.

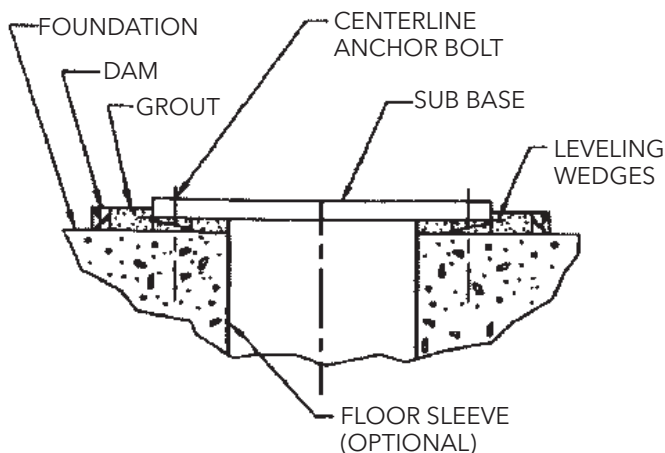

Figure 4

SUB BASE OR BARREL FLANGE GROUTING

1. Inspect foundation for dust, dirt, oil, chips, water, etc. and remove any contaminants. Do not use oil-based cleaners as grout will not bond to it. Refer to grout manufacturer's instructions.
2. Build dam around foundation (See Figure 4). Thoroughly wet foundation.

3. Pour grout between sub base or barrel flange and concrete foundation, up to level of dam. Remove air bubbles from grout as it is poured by puddling, using a vibrator, or pumping the grout into place. Non-shrink grout is recommended.
4. Allow grout to set at least 48 hours.
5. Tighten foundation bolts.

SITE WITH STRUCTURAL STEEL FOUNDATION

When the pump is mounted directly on a structural steel frame, pumps shall be located directly over, or as near as possible to, the main building members, beams or walls. The barrel, discharge head mounting flange or sub base, shall be bolted to the support to avoid distortion, prevent vibration and retain proper alignment.

PIPING

Guidelines for piping are given in the “Hydraulic Institute Standards”, available from: Hydraulic Institute, 9 Sylvan Way, Parsippany, NJ 07054-3802 and must be reviewed prior to pump installation.

⚠ WARNING *Never draw piping into place by forcing the flange connections of the pump. Pipe strain will adversely effect the operation of the pump resulting in damage to the equipment and possible physical injury.*

1. All piping must be supported independently, and line up naturally with the pump flange so that undue pipe strain is not imposed on the pump.
2. **DO NOT** connect piping to pump until grout has hardened and pump hold-down bolts have been tightened.
3. It is suggested that expansion loops or joints, if used, be properly installed in the discharge line. When handling liquids at elevated temperatures expansion joints are used, so linear expansion of piping will not draw pumps out of alignment.
4. Carefully clean all pipe parts, valves and fittings, and piping branches prior to assembly.
5. Isolation and check valves should be installed in discharge line. Locate the check valve between isolation valve and pump, this will permit inspection of the check valve. The isolation valve is required for regulation of flow, and for inspection and maintenance of pump. The check valve prevents pump or seal damage due to reverse flow through the pump when the driver is turned off.
6. Increasers, if used, should be placed between pump and check valves.
7. Cushioning devices should be used to protect the pump from surges and water hammer if quick-closing valves are installed in the system.

PUMP INSTALLATION



When pumping unit is installed in a potentially explosive environment, the instruction after the symbol must be followed. Personal injury and/or equipment damage may occur if these instructions are not followed. If there is any question regarding these requirements or equipment is to be modified, please contact a Goulds Water Technology representative before proceeding.

Pumps of 20 feet (6 m) or less in length are usually shipped assembled, with the exception of the driver, mechanical seal with tubing and coupling assembly, spacer or non spacer type. When provided, refer to the Certified Pump Outline for the applicable base plate plan for the location of anchor bolt holes.

INSTALLING A PARTIALLY ASSEMBLED PUMP

1. If a base plate was supplied, install as described in Foundation/Piping Section (page 9).
2. Clean the mounting surface of the plate and clean bottom surface of discharge head mounting flange.
3. Check that all fasteners on the pump are tight, as it is recognized that transportation and handling may result in bolt relaxation.
4. Install the barrel (can) to discharge head O-ring (743).
5. Sling through discharge head holes or thread two eyebolts through bolt holes in mounting flange and hoist unit into position over foundation.

NOTE: Eyebolts or sling should be rated to handle in excess of the pump weight (see Outline Drawing).

6. Lower the unit and carefully guide it so that unit does not strike the side of the base plate. Continue to lower unit until the discharge head flange engages and rests firmly on the plate, then secure with capscrews provided.
7. When a lineshaft is shipped separately check shaft for straightness; average total run out should not exceed 0.005” T.I.R. (0.127mm) for 10 feet (3 m). Shaft must be within tolerance prior to installation.
8. Refer to remainder of this manual for complete assembly, startup, maintenance, disassembly and recommended lubricants for the pump.

INSTALLING THE BOWL ASSEMBLY

⚠ WARNING *Do not work under a heavy suspended object unless there is positive support and safe guards, which will protect personnel, should a hoist or sling fail.*

⚠ CAUTION *Do not attempt to lift bowl assembly by the pump shaft. This can result in damaging the pump shaft.*

1. Prior to installing the bowl assembly, check that all capscrews are tight. Turn the pump shaft by hand and make sure it turns freely. Remove all accumulated dust, oil, or other foreign material from the external surfaces.
2. If a suction strainer is provided, assemble it to the suction bell (or suction bowl).

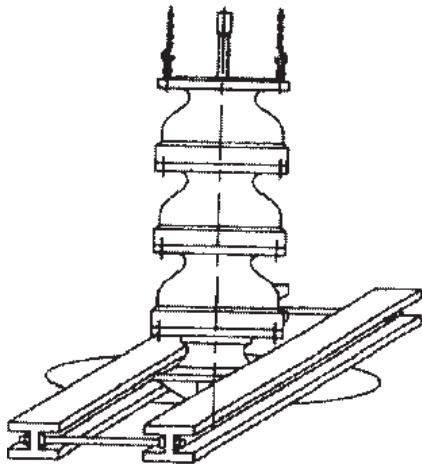

Figure 5

3. Place two I-beam supports across the base plate opening, strong enough to safely support the weight of the entire pump assembly. These I-beams should be connected by threaded rods and nuts so as to clamp them firmly together for the portion to be supported. (See Figure 5).
4. Place a suitable hoist or derrick over base plate opening with the hook in the center. Place the elevator clamps just below the discharge bowl. Place the elevator clamps just below the discharge bowl. For flanged column install two threaded eyebolts through the discharge bowl bolt holes 180° apart for flanged column. For threaded discharge utilize a lifting bail sized to handle the weight of the bowl assembly and suction apparatus. Attach a sling to the elevator clamps, eyebolts, or lifting bail and hoist it into position.
5. Carefully lower bowl assembly, guiding the unit so it does not strike the sides of the opening. Continue to lower bowl assembly until the elevator clamps or discharge bowl flange rests firmly on the I-beam supports.
6. Place a cover over the discharge bowl opening to prevent entrance of dirt or other foreign matter until ready for installation of the column assembly.

CAUTION Do not drop any foreign object into the bowl assembly. Such an object can cause serious damage to the pump and any downstream components. Any foreign object dropped into the bowl assembly must be retrieved prior to continuing assembly.

THREADED COUPLING INSTALLATION

NOTE: Shaft threads are left-handed.

When the threaded coupling is not installed on the pumpshaft, install as follows:

1. Coat a thin film of oil to the threads on the lineshaft (646) and the coupling (649) (for non-galling material, or Molykote if galling material).
2. Install threaded coupling onto pumpshaft by threading it on for one-half its length. A fine wire inserted in the drill hole at the center of the coupling can be used as a gauge to determine when the coupling is correctly positioned on the pumpshaft. Remove the wire after installed the coupling.

CAUTION Use “MOLYKOTE” Dow Corning or equal for all galling material such as 316 stainless steel.

INSTALLING THE COLUMN

OPEN LINESHAFT

Pump lineshafts are coupled with either threaded or keyed couplings. Follow only those procedures appropriate for the type of lineshaft coupling supplied.

When provided, see the Certified Pump Outline Drawing for the number of column and shaft sections required.

1. Check the headshaft (608) and lineshaft (646) for straightness. Average total runout should be less than 0.0005” T.I.R. per foot, not to exceed 0.005” T.I.R. for every 10 feet of shafting.
2. Hoist the first piece of lineshaft over the bowl assembly. Lower the lineshaft until the bottom end is properly aligned with the coupling of the pump shaft. Apply a thin film of oil to the threads on the lineshaft (646) and the coupling (649) (for non-galling material, or Molykote if galling material).

CAUTION Use “MOLYKOTE” Dow Corning or equal for all galling material such as 316 stainless steel.

- 3a. With lineshaft in the proper position on the coupling, screw lineshaft into the coupling manually until resistance is felt. A fine wire inserted in the hole at the center of the coupling can be used as a gage to determine when the coupling is correctly positioned on the shaft. **Remove the wire after installing the shaft.** Completely tighten the joint by using a pair of pipe wrenches. Use care not to damage any bearing journal areas on the shaft. **NOTE: Shaft threads are left-handed.**

3b.

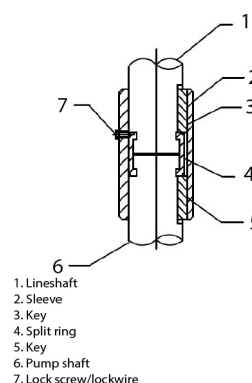

1. Lineshaft
 2. Sleeve
 3. Key
 4. Split ring
 5. Key
 6. Pump shaft
 7. Lock screw/lockwire
- With a keyed coupling insert the key into the pump shaft. Lower the sleeve over the pump shaft, to approximately 1.0 in (25.4 mm) below the top of the shaft. Then lower the lineshaft until it touches the pump shaft. Insert the split ring into the grooves of the pump shaft and lineshaft. Raise the sleeve until it covers the split ring, then insert the key into the lineshaft. Raise the sleeve to the top of the key and secure the sleeve to the split ring with a lock screw and lock wire.

4. Install two eyebolts diametrically opposite the upper flange of the bottom column (644). Attach a sling to the eyebolts and to the hoist hook. Lower column section until the flange engages the flanged top bowl register. Insert as many bolts through both flanges as possible. Lift column assembly high enough to allow rotation of the supports. Install and tighten remaining capscrews gradually in diametrically opposite pairs until all are uniformly tightened.
5. Lift the assembly and remove the elevator clamp or supports and slowly lower the bowl and the column assembly. Place supports on the base plate and continue to lower the assembly until the column elevator clamps or column flange comes to rest on the supports.

NOTE: Normally, the bearing retainer will be integral with column. The top flange of the column will have male register and the bottom flange of the column will have a female register. If you have separate bearing retainers, there will be a female register in the flange at both ends of the column. Follow step 6 below.

6. Place the bearing retainer (652) with bearing (656) over the shaft and fit the retainer in the female register of the flange. Make sure the contact faces in the flanges are clean. Use a file to remove nicks or dings.
7. Install threaded coupling (649) on the protruding end of the lineshaft (646), if required.
8. Assemble next column (642) section, or top column (641) as required, and make sure bottom column register (or bearing retainer (652)) engages the top column register, and secure with capscrews (760B) and hex nuts (735A) provided. Tighten capscrews into hex nuts gradually and uniformly.
9. Repeat the preceding procedures until all column sections required have been installed.

CAUTION Do not drop any foreign object into the column assembly. Such an object can cause serious damage to the pump and any downstream components. Any foreign object dropped into the column assembly must be retrieved prior to continuing assembly.

INSTALLING THE DISCHARGE HEAD

VIC Pumps are provided with either “T” type or “L” type head. Install the discharge head as follows:

1. If the stuffing box (See Fig. 6) is assembled to the head, remove it and all the attached piping.
2. When a mechanical seal is provided it is shipped separately.
3. Remove coupling guard if provided. Attach a sling to the lifting lugs on the side of the discharge head or through windows and hoist discharge head over the protruding top shaft.

WARNING Eyebolts or sling should be rated to handle in excess of the pump weight (see Outline Drawing).

CAUTION Do not bump or scrape the shaft protruding above the column. This could result in bending or damaging the shaft.

4. Orient the discharge head in the required position and lower the head. Centering the vertical hole with the top shaft protruding above the column until the discharge head engages the column flange. Install capscrews and secure discharge head to the column flange. Tighten capscrews gradually in diametrically opposite pairs.
5. Lift the pump assembly high enough to allow rotation of the supports. Realign and lower assembly. Install and tighten remaining capscrews. Repeat the rotating and the tightening procedure until all capscrews are uniformly tight.
6. Hoist the discharge head by lifting lug and remove the elevator clamp attached to column.
7. Remove the support timbers or I-beams and clean the top of barrel flange. Orient the discharge head in the required position.

NOTE: Sling should be rated to handle in excess of the pump weight.

8. Lower bowl, column and head assembly, until discharge head mounting flange engages with the barrel flange. Secure discharge head to barrel. Check the levelness of the discharge head in all directions, utilizing a machinist level across the driver’s mounting surface of the discharge head.
9. Check whether the top shaft (or stub shaft) is in the center of the stuffing box bore. If not, the shaft must be centered by shimming the head base and the sub base (or the foundation).
10. Rotate the shaft approximately 90°. Check again whether the shaft is at the center of the stuffing box bore or not. If not, either the top shaft is bent or the first shaft below it did not butt properly. Correction must be made before the installation procedures can proceed.

INSTALLING THE STUFFING BOX

Assemble stuffing box as shown in Figure 6.

1. Clean the surface of the discharge head where the stuffing box will be mounted and remove any nicks or burrs with a fine flat file. Position gasket on surface. Slide stuffing box (616) down over headshaft and into position on the gasket. Secure stuffing box with capscrews.
2. Grease the packing ring (620) for easier installation.
3. Twist the packing ring sideways to get it around the shaft easily. Start the first ring into the stuffing box. When the entire ring is worked in using the fingers, tamp it down using a split wood bushing (or equal) and push the packing ring down firmly. It must seal on the shaft and bore of the stuffing box. Install three (3) rings in this manner. Stagger ring joints 90 degrees apart. The split gland may be used as a tamper for the top ring.
4. Insert lantern ring (622) into stuffing box. Be sure it is properly positioned so that it aligns with the lubrication passage in the stuffing box.
5. Insert three (3) additional rings of packing. Stagger ring joints 90° apart.
6. Install the split gland and screw nuts on the split gland studs. Tighten nuts then relieve the nuts and tighten finger tight.

CAUTION Check that the split gland is square in the stuffing box. Cocking can cause uneven compression of packing and damage to the shaft or sleeve and heat up the shaft and stuffing box.

- The stuffing box is shipped with both ports plugged. If the discharge pressure is over 100 psi, remove the plug on Port "A" and attach a bypass (relief) line. If the discharge pressure is over 200 psi, remove the plug on Port "B" and attach another bypass line.
- Final adjustment of the stuffing box must be made at pump start up.
- A properly packed stuffing box should be loose enough to allow the shaft to be turned manually and must have leakage (see page 21 – Packing Adjustment).

CAUTION Do not over tighten packing or excessive wear can occur on the shaft or sleeve.

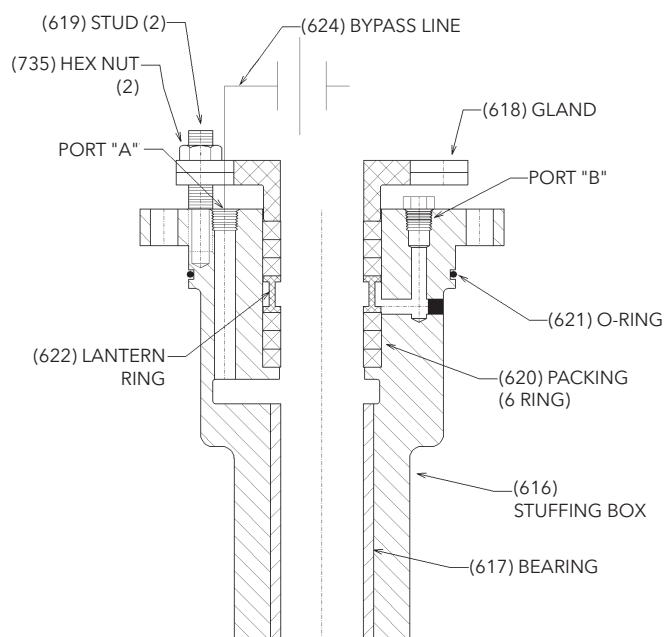

Figure 6

INSTALLING THE MECHANICAL SEAL

The vertical turbine pumps are usually supplied with cartridge type mechanical seals, shipped assembled - ready for installation, when mechanical seals are supplied. Instructions for installing mechanical seals are provided by the seal manufacturer. Consult the seal manufacturer's instructions (furnished with the seal) for information on the type of seal used. Additionally, refer to factory furnished outline drawing and seal piping schematic on complex seal piping arrangements.

GENERAL REQUIREMENTS FOR ALL SEALS

- Check surfaces at the face of the seal housing and at the bottom of the seal housing to insure that they are clean, flat and free of burrs. The face surface must be smooth to form a good sealing surface for a gasket or O-ring.
- Check that shaft is smooth, and free of burrs, nicks and sharp corners that could ruin the O-ring or

shaft packing. When further clean up is required, protect by covering the inside of the pump seal housing. Remove burrs, nicks and sharp corners by using a strip of emery cloth over the shaft threads. File threads around the keyway with a smooth mill file or emery cloth. Sharp edges must be rounded.

- Remove all chips and dust from the shaft area.
- Check that all rotary unit parts of the seal fit over the shaft. A pre-check may be made by removing the O-ring(s) from the cartridge sleeve Inside Diameter (ID) and then installing the seal on the shaft. Further shaft clean up will be necessary when the seal will not pass all the way into the seal housing.
- Remove the seal after the pre-check, and re-install the sleeve O-ring(s).
- Sparingly lubricate the shaft and sleeve ID with the lubricant included with the mechanical seal or recommended by the mechanical seal manufacturer. The following lubricants may be used, for water service, when no lubricant is supplied or recommended by the mechanical seal manufacturer.

- Light oil (SAE #10 or 20)
- Dow Corning #4 Grease
- Silicone lubricant
- Wax or clay
- Soapy water

Oil based lubricants will damage EPR / EPDM elastomer O-rings. Silicone lube and soapy water are safe for EPR / EPDM elastomer O-rings.

- Install the O-ring or gasket, between the seal housing and seal. Install the seal over the shaft and ease it into position against the face of the seal box. Take care when passing the sleeve and O-ring over keyways or threads to avoid damaging the O-ring.

CAUTION Do not bump carbon members against the shaft as they may chip, crack or break.

- Position seal gland on discharge head seal housing and secure with capscrews (or nuts for studs) provided. Tighten capscrews gradually and uniformly in a criss-cross pattern, taking 2 or 3 passes.

CAUTION Do not over tighten capscrews on gland. This can distort seal seat and cause seal failure.

- Install all seal piping as required. Prior to making final connections of sealing liquid pressurizing lines, make sure the seal housing and all sealing liquid lines are flushed free of dirt, scale and other particles that would be abrasive to the sealing faces.
- The Driver and Coupling must now be installed before the driver installation can proceed. See page 14 - INSTALLATION OF A HOLLOW SHAFT DRIVER or page 15 - INSTALLATION OF A SOLID SHAFT DRIVER as appropriate.

INSTALLING THE DRIVER



When installed in a potentially explosive environment, please ensure the motor is properly certified.

WARNING Serious damage may result if pump is run in the wrong direction.

NOTE: When pump is supplied with a thrust pot, do not secure the driver to discharge head until after the thrust pot and flexible coupling are installed.

INSTALLATION OF A HOLLOW SHAFT DRIVER

This refers to either VHS type electric motors or hollow shaft type gear drives. A small paragraph will be devoted to combination electric motor and right angle gear drives.

WARNING Do not work under a heavy suspended object unless there is a positive support and safe guards which will protect personnel should a hoist or sling fail.

1. The driving mechanism of all hollow shaft driver is shown on Figure 7. The head shaft (608) extends up through the quill or hollow shaft of the driver and is held in place by an adjusting nut (604), which not only carries all the static and hydraulic thrust of the impellers and shaft, but also provides the adjustment for the impeller clearances. The head shaft is connected to top shaft (or stub shaft) by a threaded coupling or a rigid flange coupling.
2. Attach a sling to the lifting lugs of driver and hoist the driver up. Inspect the mounting surface, register and clean these surfaces thoroughly. If any burrs are found, remove burrs with a smooth mill file, cleaning thoroughly afterward.
3. For motor, orient the motor conduit box in the required position. For the right angle gear, orient the input shaft to the desired position. Align the driver mounting holes with the mating tapped holes on the discharge head. Lower the driver until the registers engage and the driver rests on the discharge head. Secure driver with capscrews provided.
4. Lubricate the driver bearings in accordance with instructions given on lubrication plate attached to the driver case. (Or refer to IOM of the driver)
5. After lowering and orienting the driver as explained above, remove the drive coupling and the hold down bolts (See Figure 16). **Be sure to mark the location of the coupling before removing it.**

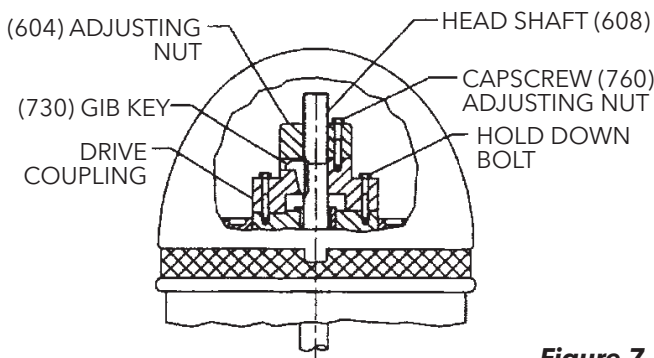

Figure 7

6. Lower the head shaft through the motor quill shaft to meet the shaft coupling. Apply a thin film of oil to head shaft threads (if non-galling material) and screw into the shaft coupling (located above the stuffing box). Make sure the shaft is not damaged in any way. Tighten the joint.
7. Check that the head shaft centers inside the driver quill shaft within 0.06" (1.5mm). If it does not, misalignment is indicated.
8. Any head shaft misalignment with driver quill shaft could be caused by a bent head shaft, burrs, or foreign matter between shaft ends or any of the mounting flanges: motor flange to discharge head top flange, discharge head base flange to base plate or the base plate itself could be out of level. If the latter, shimming between it and discharge head base, will correct it. Also, check concentricity of motor to motor-stand (if provided) to discharge head.
9. With the motor in place and the head shaft projecting through the motor quill shaft, make temporary electrical connection to check the motor rotation. **(Be sure to remove the ratchet pins or balls before checking motor rotation.)** Motor must rotate counter-clockwise when viewed from the top. See arrow on pump name plate. If motor does not rotate counter-clockwise, you can change the rotation by interchanging any two leads.

CAUTION Never check motor rotation with the drive coupling in place. The bore clearance between the drive coupling and the pump shaft O. D. is so close that should the motor spin with this shaft stationary, galling and locking together is very likely to take place.

10. Install motor drive coupling. **(Be sure to line up the match mark made at step 5.)** Insert the ratchet pins if a non-reverse ratchet is used. Match the coupling lugs with corresponding holes in motor. Tighten hold down bolts evenly, making sure driver coupling is properly seated in the register fit.
11. Fit gib key (730) into keyway, by filing if necessary, to where there is a snug but sliding fit. This key must be able to be removed by gentle leverage with a screwdriver under it.
12. Be careful that the gib key (730) is not too high so as to hold up the adjusting nut (604) from seating on the drive coupling. If it is, cut off some length of the key.
13. Install adjusting nut (604) to hand tight.

COMBINATION ENGINE AND MOTOR DRIVES

1. On combination drivers, the motor is invariably on top with a projecting head shaft extension.
2. Follow all procedures outlined in the previous paragraph, except that the motor must be lowered over this extended head shaft and great care must be taken to center it exactly so as not to bump or misalign the shaft while the motor is being lowered into place.

- There are several methods of running engines without electric motors and vice versa, requiring simple adjustment to the combination drive, but they are too numerous to mention here and can be obtained from the gear manufacturers instructions included with the shipment.

IMPELLER ADJUSTMENT FOR ALL HOLLOW SHAFT DRIVES

NOTE: Shaft adjustment up or down is accomplished by turning the adjusting nut (604) Figure 8.

NOTE: There are five holes in the adjusting nut and only four in the motor coupling. See Figure 8.

- With shafting all the way down and the impellers resting on their seats, turn the adjusting nut (604) in counter-clockwise direction, thus lifting the shaft, until the impellers just clear their seats and the shaft/motor turns free by hand. This removes all deflection from the shaft.

(604) ADJUSTING NUT

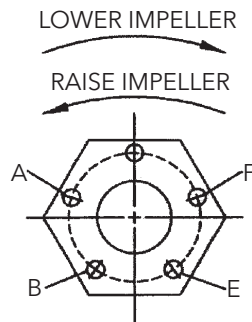

- For enclosed impellers, make another two turns on the adjusting nut. (3 turns for 12 thread/inch shaft) Line-up one of the holes in the adjusting nut with the nearest hole in the driver coupling. Insert the capscrew in the hole and tighten it.

MOTOR COUPLING

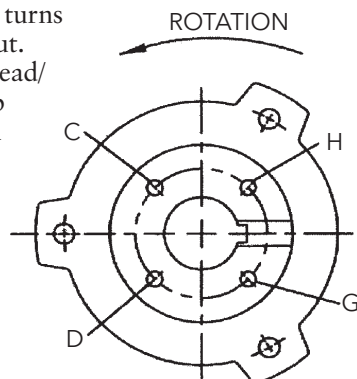

Figure 8

NOTE: 1.00" and 1.18" diameter shafts are 12 thread per inch (tpi), 1.50" through 2.44" are 10 tpi, all larger sizes are 8 tpi.

- For Open Impellers, Align hole "A" in the adjusting nut (604) and hole "C" in the driver coupling (See Figure 8) or whatever similar holes are in like position. If care is exercised, this will give an initial impeller clearance of 0.001" to 0.003" depending on shaft size or the pitch of the thread.
- Insert capscrew into hole "B" provided these are the nearest matching holes for counter-clockwise rotation of adjusting nut, turn adjusting nut counter-clockwise until holes "B" and "D" line up. This gives 1/20 of a turn which is 0.004" on 12 tpi shaft or 0.005" on 10 tpi shaft.

- Normal impeller clearance for the open impeller is considered to be 0.015" for the first 10 feet of the column length and 0.010" additional clearance for each 10 ft of length thereafter. This can be reduced in some instances where is necessary, but should not be attempted without consulting the factory or factory serviceman is present.

INSTALLATION OF A SOLID SHAFT DRIVER

NOTE: When pump is supplied with a thrust pot, do not secure driver to discharge head until after the thrust pot and flexible coupling are installed.

⚠ WARNING Do not work under a heavy suspended object unless there is a positive support and safe guard which will protect personnel should a hoist or sling fail.

The coupling between the driveshaft and the head shaft may be a non-spacer type (see Figure 9), or a spacer type (see Figure 10). The latter is used on pumps furnished with a mechanical seal to permit servicing of the seal without removal of the driver.

- Attach a sling to the lifting lugs of driver, hoist motor, inspect the mounting surface, register, and shaft extension, and clean these surfaces thoroughly. If any burrs are found, remove burrs with a smooth mill file, cleaning thoroughly afterward.
- Orient the motor conduit box in the required position. Align the motor mounting holes with the mating tapped holes on the discharge head. Lower the motor until the registers engage and the motor rests on the discharge head. Secure motor with capscrews provided.
- On drivers having a nonreverse ratchet or pins, manually turn the driver shaft clockwise viewed from the top until the nonreverse ratchet or pins fully engage.
- Lubricate motor bearings in accordance with instructions given on lubrication plate attached to the motor case.

NOTE: Please read and follow the motor manufacturer's instructions before lubricating the motor bearings. Too much lubricant can cause the bearings to overheat prematurely.

⚠ WARNING The motor must not be tested for direction of rotation when coupled to the pump. If pump should rotate in the wrong direction, serious damage to the pump and motor would result. Also serious injury to personnel could result.

- Make temporary electrical connections according to tagged leads or diagram attached to the motor. Motor must rotate counterclockwise when viewed from the top. See arrow on pump name plate. If motor does not rotate counterclockwise, you can change the rotation by interchanging any two leads.
- Motor shaft end play adjustment: if required, motor shaft end play shall be checked with a dial

indicator prior to connecting the pump coupling to the solid shaft motor. Consult the applicable motor manufacturers instruction manual for detailed information on motor shaft end play.

COUPLING INSTALLATION: (SEE FIGURES 9 and 10)

1. Check all mating faces with a fine flat file before installation. Remove all burrs from face.
2. Apply a thin film of oil on the pump key (730) and insert key into headshaft keyway seat.
3. Gently lower pump hub of coupling (614) onto headshaft.
4. Thread on the adjusting plate (613) onto the headshaft until flush with top of the headshaft.
5. Clean driver shaft by removing all grease and burrs. Try to fit the key on the driver hub (610) before installing it to the driver shaft.
6. Apply a thin film of oil to the driver key (730) and insert key into drive shaft keyway seat. Place the driver hub (610) onto the drive shaft and with key slide it up the drive shaft until the annular groove is exposed. Install split ring (722) in the groove and slide driver hub down over the split ring to capture it.

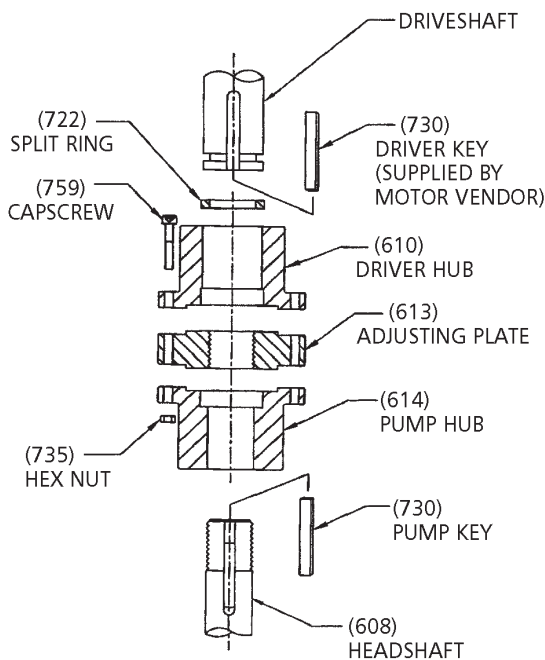

Figure 9

7. If the pump is supplied with an adjustable spacer coupling (see figure 10), install spacer (612) between head shaft and driveshaft hubs. Secure with cap screws (759) and hex nuts (735).

IMPELLER ADJUSTMENT



Improper impeller adjustment could cause contact between the rotating and stationary parts, resulting in a spark and heat generation.

Impeller adjustment is identical for all motors and right angle gear drives. Adjustment is accomplished by turning the adjusting plate (613). (See figure 11 or 12). The correct adjustment is listed on the Outline Drawing for the specific unit. **If the pump has thrust pot, do not adjust the impeller position until the thrust has been installed and adjust the impeller position by using the adjust nut on the thrust pot.**

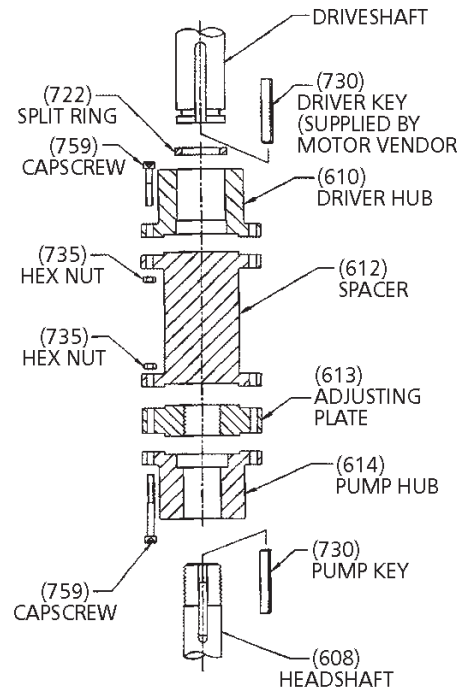

Figure 10

NOTE: Mechanical seal, when provided, must not be secured to the shaft prior to impeller adjustment. (open or enclosed type impellers). Shaft must move up or down within the seal Assembly.

For pumps handling liquids between -50° to 200° F, impeller adjustment can be made under ambient conditions. For liquids in excess of this range, it is recommended that impeller adjustment be made after the pump surface temperature has reached an equilibrium when charged with the pumpage. In those cases, where this is not feasible due to safety consideration or impossible due to external ice build up in cryogenic applications, refer to factory for specific instructions.

OPEN IMPELLERS

1. With the impellers touching the bottom of the bowls, turn the adjusting plate (613) towards the driver hub (610) or spacer (612) obtain 0.015 inch clearance between the adjusting plate and driver hub or spacer for the first 10 feet of column. Add 0.010" for each additional 10 feet of column. See figure 10 or 11. **Note:** The determination of driver shaft end play can be critical and should be added to this setting. For larger pumps over 8", this amount may be too little; please refer to Outline Drawing.

2. After impeller adjustment, align adjusting plate (613) with the pump hub (614), and tightly draw coupling flanges together with capscrews (759) and nuts (735). (See figure 9 and 10).
3. Check shaft run out with dial indicator. For mechanical seal installation, the run out should be 0.005 or less.
4. Set seal after impeller adjustment. Securely tighten all set screws in the collar. Remove the spacer between the gland plate and collar. Retain spacer for future resetting of seal.

NOTE: When impellers are reset, the seal must also be reset.

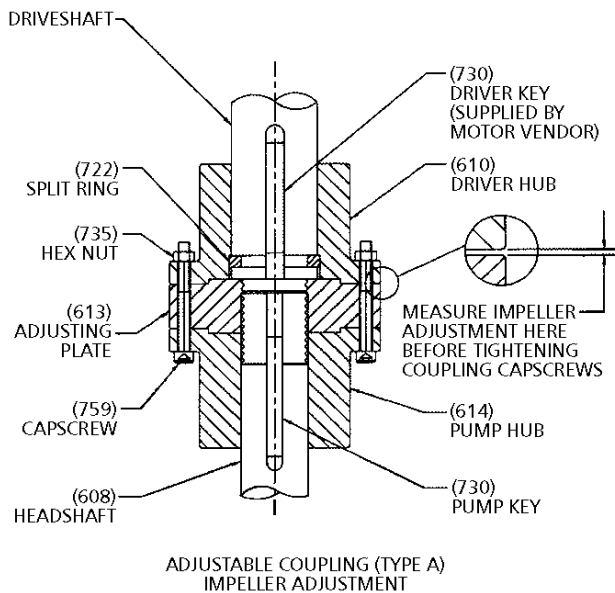

Figure 11

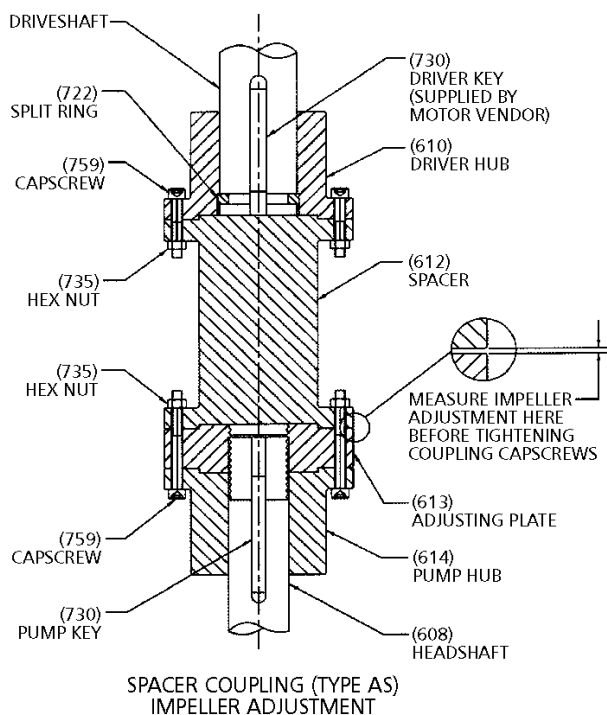

Figure 12

ENCLOSED IMPELLERS

For enclosed impellers obtain the clearance between the adjusting plate and driver hub or spacer as specified on the outline drawing. See Figure 11 or 12.

INSTALLING THE GREASE LUBRICATED THRUST POT

This type of thrust pot and the motor stand are assembled on the discharge head by the factory. This thrust pot is designed to be used with NEMA Vertical C-face motors. The motor shaft and the pump shaft have to be coupled with flexible coupling.

INSTALLATION:

1. Install both coupling halves prior to mounting the motor. Refer to the coupling manufacturer's instructions.
2. Using the lifting lugs on the motor, carefully lower the motor onto the motor stand of the thrust pot (See Figure 13) and align the bolt holes.
3. Install the bolts finger tight.
4. Make temporary electrical connections according to tagged leads or diagram attached to the motor. Motor must rotate counterclockwise when viewed from the top. See arrow on pump name plate. If motor does not rotate counterclockwise, you can change the rotation by interchanging any two leads.

WARNING

Before beginning any alignment procedure, make sure driver power is locked out. Failure to lock out driver power will result in serious physical injury.

ALIGNMENT OF FLEXIBLE COUPLING:

Alignment of the pump and motor is extreme importance for trouble-free mechanical operation. Straight edge alignment by an experienced installer proves adequate for most installations.

1. Check for coupling alignment by laying a straight edge across both coupling rims at four points 90° apart.
2. Move motor until straight edge rests evenly at each position. Repeat procedure until correct alignment is achieved.
3. Install flexible sleeve between the hubs per the manufacture's instructions.
4. Tighten all motor bolts.

NOTE: Be sure the relief fitting (#11 in Figure 13) is clear of paint or any other obstructive material. Otherwise it will cause premature failure of the thrust pot and is not covered under warranty.

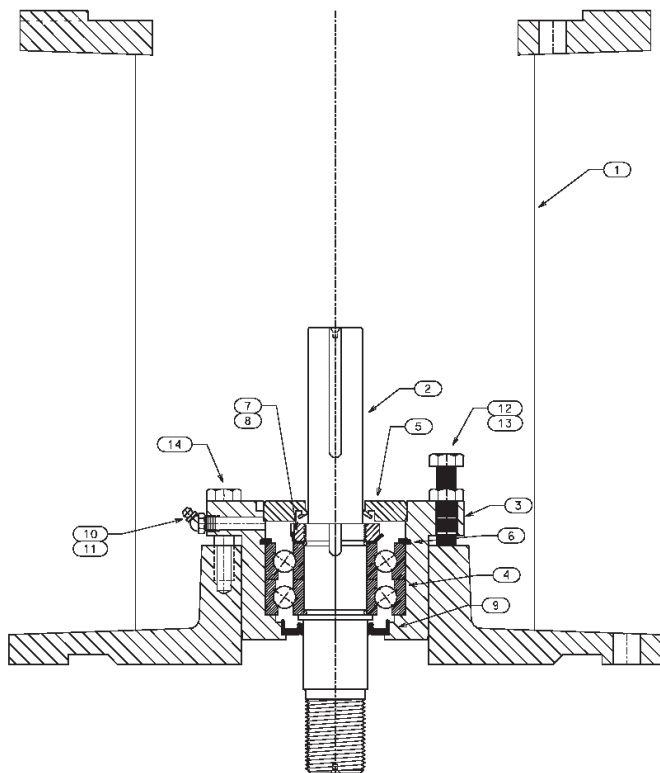

ITEM	DESCRIPTION
1	Motor stand
2	Headshaft
3	Bearing housing
4	Bearing
5	Top seal
6	Snap ring
7	Lock nut
8	Lock washer
9	Lower seal
10	Grease lube fitting
11	Grease relief fitting
12	Hex tap bolt
13	Hex nut
14	Hex capscrew

Figure 13 - Grease Lubricated Thrust Pot

INSTALLING THE OIL LUBRICATED THRUST POT

If the unit is supplied with a thrust pot (see Figure 14), the thrust pot should be installed on top of the discharge head or motor stand before installing the driver. The driving mechanism of the thrust pot assembly is similar to the hollow shaft motor. (See Figure 7)

1. Attach a sling to the thrust pot assembly through the windows on the motor adapter and hoist the assembly over the top of the discharge head.
2. Clean the mounting face with a flat file to remove any burr of the discharge head and the thrust pot. Lower the thrust pot assembly and orient it so that the bolt hole on the base of the thrust pot and the top flange of the discharge head are lined up. Install all the bolts to secure the assembly to the discharge head.

3. Lower the drive shaft through the quill of the thrust pot assembly to meet the shaft coupling. Apply a thin film of oil to the head shaft thread and screw into the shaft coupling.
4. For unit with mechanical seal and flanged coupling, install the spacer flange coupling as instructed on page 16.
5. Install the gib key (#16) into the drive shaft and the hollow shaft clutch.
6. Install the adjusting nut (#17) to hand tight.
7. With shafting all the way down and the impellers resting on their seats, turn the adjusting nut (#17) in counter-clockwise direction, thus lifting the shaft, until the impellers just clear their seats and the shaft/motor turns free by hand. This removes all deflection from the shaft.
8. Line-up one of the holes in the adjusting nut with the nearest hole in the driver coupling. Insert the capscrew in the hole and tighten it.

NOTE: 1.00" and 1.18" diameter shafts are 12 tpi, 1.50" through 2.44" are 10 tpi, all larger sizes are 8 tpi.

9. Install the bottom of the flexible coupling to the top of the drive shaft.
10. Attach a sling to the lifting lugs of driver and hoist the driver up. Inspect the mounting surface, register and clean these surfaces thoroughly. If any burrs are found, remove burrs with a smooth mill file, cleaning thoroughly afterward. Temporarily attach the top half of the flexible coupling to the motor shaft.
11. Orient the motor conduit box in the required position. Align the driver mounting holes with the mating tapped holes on the discharge head. Lower the driver until the registers engage and the driver rests on the thrust pot assembly. Secure driver with capscrews provided.
12. Secure the flexible coupling assembly.
13. Install the coupling guard.
14. Fill the oil reservoir with recommended oil.

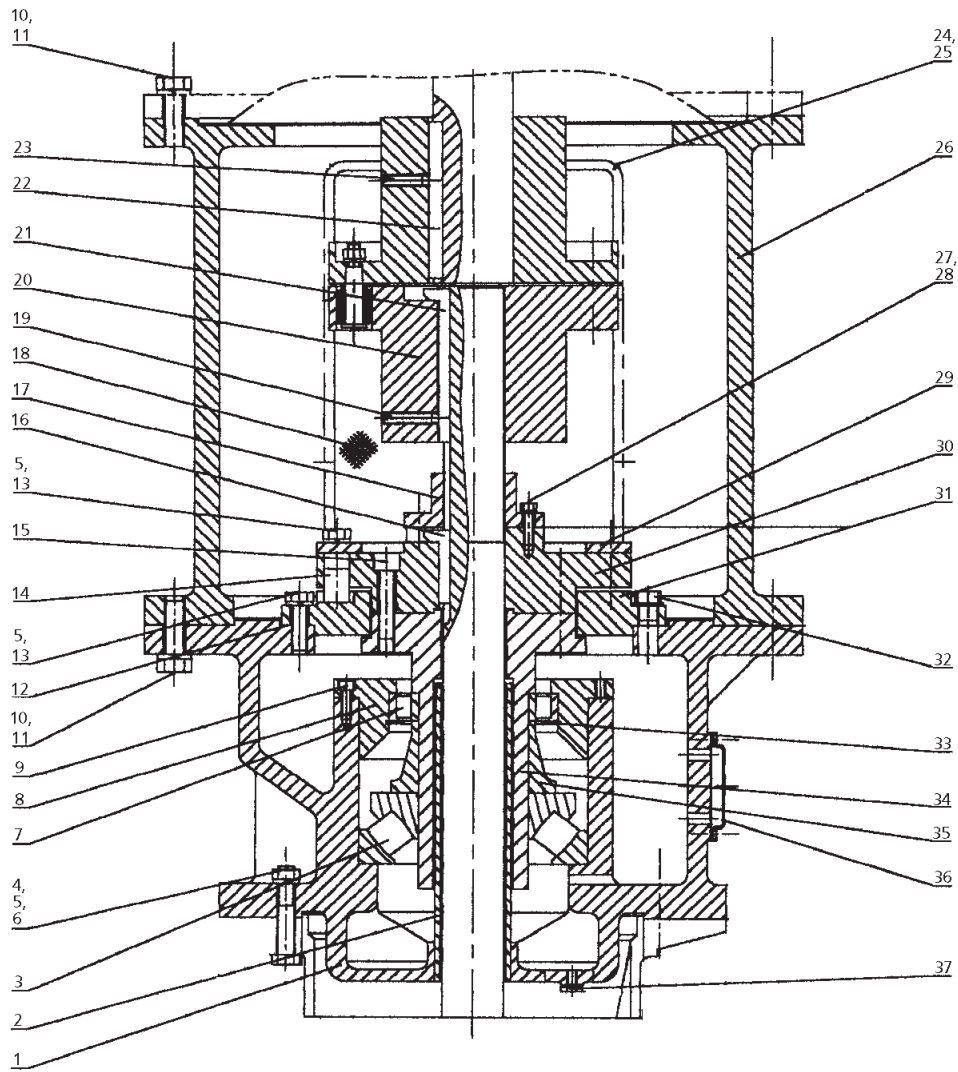

ITEM	DESCRIPTION
1	Thrust Pot Body
2	Tube - Oil Retaining
3	Thrust Bearing
4	Capscrew - Head to Thrust Pot
5	Washer - Head to Thrust Pot
6	Hex Nut - Head to Thrust Pot
7	Roller Bearing
8	Bearing Seat
9	Allen Head Screw
10	Capscrew - Motor Adapter to Motor or Thrust Pot
11	Washer - Motor Adapter to Motor or Thrust Pot
12	Gasket
13	Capscrew
14	Non-reverse Pin
15	Socket Head Screw
16	Gib Key
17	Adjusting Nut
18	Coupling Guard
19	Setscrew

ITEM	DESCRIPTION
20	Flexible Shaft Coupling
21	Gib Key
22	Key (Motor Shaft)
23	Setscrew
24	Round Head Screw for Coupling Guard
25	Washer Coupling Guard
26	Motor Adapter
27	Capscrew - Adjusting Nut
28	Washer - Adjusting Nut
29	Retaining Ring
30	Hollow Shaft Clutch
31	Non-reverse Plate
32	Pipe Plug - Oil Filling
33	Retaining Ring
34	Hollow Shaft
35	Shaft Sleeve
36	Sight Gauge
37	Pipe Plug - Oil Drain

Figure 14 - Oil Lubricated Thrust Pot

Pump Startup And Operation – SECTION 4

PRE-START PROCEDURE

Consult the applicable manufacturer's instructions for detailed information for the prime mover (electric motor, engine or steam turbine), coupling, driveshaft, gear driver. Prior to startup, check the following:

1. Confirm that the following procedures described in the "Installing the Drivers" sections have been performed:
 - A. Wiring of Driver.
 - B. Driver must rotate counterclockwise (CCW) when viewed from above.

▲WARNING *Serious damage may result if pump is run in the wrong direction.*

▲WARNING *Do not check motor rotation unless motor is bolted to pump and drive coupling is match marked and removed.*

▲WARNING *Be sure to install the coupling guards around all exposed shafts and couplings before start up of the pump. Failure to comply may result in severe personnel injury or death.*

- C. Check alignment of pump and driver.
 - D. Impeller adjustment has been made.
 - E. Mechanical seal lock collar is attached to shaft.
2. For open lineshaft pump, make sure the stuffing box relief (bleed) line is connected (if applicable).
 3. For pump with mechanical seal, make sure mechanical seal is properly lubricated and all piping to seal is connected. Also, check that all cooling, heating and flushing lines are operating and regulated.
 4. Open the air release system isolation valve. Adjust the air release system throttling device so that it is partially open. It should not be closed or fully open.

NOTE: Not exhausting the air or exhausting it too fast can damage the pump.

5. All connections to driver and starting device match wiring diagram. Voltage, phase, and frequency on motor nameplate agree with line current.
6. Rotate shaft manually to ensure impellers are not binding.
7. Verify that driver bearings are properly lubricated and check oil level in housing.
8. Check that auxiliary seal components are properly vented.
9. Inspect discharge piping connection, valves and pressure gauges for proper operation.

STARTUP PRECAUTIONS

1. All equipment and personal safety related devices and controls must be installed and operating properly.
2. To prevent premature pump failure at initial start-up due to debris in the pipe system, ensure the system has been adequately cleaned and flushed.
3. Variable speed drivers should be brought to rated speed as quickly as possible.
4. Variable speed drivers should not be adjusted or checked for speed governor or over-speed trip settings while coupled to pump at initial startup. If settings have not been verified, uncouple the unit and refer to driver manufacturer's instructions for assistance.
5. Running a new or rebuilt pump at slow speeds may not provide enough flow to adequately flush and cool the stuffing box bushing's close running surfaces.
6. Pumpage temperatures in excess of 200° F (93° C) will require warm-up of pump prior to operation. Circulate a small amount of pumpage through the pump until the casing temperature is within 100° F (38° C) of the pumpage temperature and evenly heated.

PRIMING

▲CAUTION *The pump must be properly vented through the discharge head/barrel vent connections. This is especially important for fluids with suction pressure close to their vapor pressures. Vent piping must be continuously rising back to source so that fluid cannot collect in the vent line.*

The first stage impeller must always be completely submerged. Pump must not run dry as the rotating parts within the pump may gall and seize to the stationary parts. The parts must be lubricated by the liquid being pumped.

NOTE: NPSHa must always exceed NPSHr as shown on Goulds Water Technology performance curves.

NOTE: Pump must never be throttled on the suction side by allowing suction strainer to become clogged.

PUMP STARTUP

1. Partially close the valve in the discharge line.
2. Crack open suction side valves on pressurized systems slowly. Open suction valves fully.
3. Vent system when the pump surface temperature has reached an equilibrium.
4. Start the pump. If any abnormal noises, jerking or vibration is noted, stop the pump immediately, determine the cause of the abnormalities and correct them.

- After the pump is operating at full speed, slowly open discharge valve. If driver overheats or there is excessive vibration, stop the pump, determine the causes and correct them.



Improper impeller adjustment could cause contact between the rotating and stationary parts, resulting in a spark and heat generation.

- If the air release valve is manually operated, close it.
- For open lineshaft pumps, with the pump in operation, there should be some leakage at the stuffing box packing. The correct leakage rate is approximately one drop per second. Check the temperature of the leakage as well as the discharge head. If the pump runs hot and the leakage begins to choke off, stop the pump and allow it to cool down. A few light taps with a hammer on the gland will upset the packing sufficiently to resume leakage. After pump has cooled, restart pump and follow preceding procedure. Run pump 15 minutes, check leakage. If it exceeds two drops per second, adjust packing as described in “Packing Adjustment and Replacement”.
- For pump with mechanical seal, if seal leaks slightly at startup, allow a reasonable amount of time for seal to adjust itself. Liquids with good lubricating qualities normally take longer to wear in the seal than liquid with lesser qualities. When a seal starts out with a slight leak and gets progressively less while running, it is indicative of leakage across the seal faces. Continued running will eliminate this. Where leakage occurs immediately and remains constant, unaffected by running, it usually indicates secondary seal (Shaft packing) damage, or seal faces are warped out of flat.

Maintenance – SECTION 5

PREVENTIVE MAINTENANCE

⚠ WARNING *Before initiating maintenance procedures, disconnect (utilizing proper logout/tagout procedures) all energy sources to the equipment and accessories and completely discharge all parts and accessories which retain electric charge. Failure to comply may result in severe personnel injury or death.*

Preventive maintenance includes periodic inspection of oil level in the oil reservoir (for pump with oil lube column), re-lubrication of electric motors, gear drives and prime mover. Systematic inspection of the pump and its components shall be made at regular intervals. The frequency required depends upon the operating conditions of the pump and its environment. See following Preventive Maintenance Schedule. Consult the applicable manufacturer’s instructions for detailed information on maintenance for the prime mover, driveshaft, electric motors and gear drives. Any deviation in performance or operations from what is expected can be traced to some specific cause. Variances from initial performance will indicate changing system conditions, wear, or impending breakdown of the unit.

PREVENTIVE MAINTENANCE SCHEDULE

PROCEDURE	TIME INTERVAL (in operating hours)
Clean dirt, oil and grease from driver and discharge head.	As required
Clean driver ventilation passage to prevent overheating.	As required
Change lubrication in gear drive.	2,000 or once a year
Tighten all loose bolts and check for excessive vibration.	As required
If packing is grease lubricated, add as required.	100
Check that there is some leakage through stuffing box while pump is in operation. Do not tighten gland nuts unless necessary.	As required
Maintain a liquid film of lubrication between the seal rubbing faces.	As required
Re-grease the motor bearings: 1800 RPM and above Below 1800 RPM	Refer to Motor IOM Refer to Motor IOM

PACKING ADJUSTMENT AND REPLACEMENT

Pumps equipped with packing, shall be adjusted whenever the leakage rate exceeds two drops per second. If there is no leakage or the stuffing box overheats, do not back off gland nuts while the pump is running. This will allow the entire set of rings to move away from the bottom of the box, without relieving pressure of the packing on the shaft. Stop the pump and allow packing to cool then restart the pump.

⚠ WARNING *Be sure to reinstall the coupling guard before restarting the pump.*

It may be necessary to repeat this procedure several times before proper amount of liquid comes through to efficiently prevent overheating. If leakage is excessive, adjust the stuffing box as follows:

- With the pump in operation, tighten the gland nuts one-quarter turn for each adjustment. Allow packing to equalize against the increased pressure and leakage to gradually decrease to a steady rate, before making another adjustment.

⚠ CAUTION *Do not over tighten the stuffing box. Excessive pressure can wear out packing prematurely and seriously damage the shaft.*

- With the pump shut down and when packing has been compressed to the point that the gland is about to contact the upper face of stuffing box, remove the split gland, add one extra packing ring and readjust. If this fails to reduce leakage to two drops per second, remove all packing rings and replace with new rings.
- Remove the packing with the aid of a packing hook. If a lantern ring is provided, remove it by inserting a wire hook in the slots of the ring and pull it from the packing box. Thoroughly clean the stuffing box of all foreign matter.

- If the replacement packing is in the form of a continuous coil or rope, it must be cut into rings before installing. Tightly wrap one end of the packing material around the top shaft like one coil spring, and cut through the coil with a sharp knife. For re-packing sequence, refer to “Installing the Stuffing Box” (page 12).

THRUST POT LUBRICATION AND MAINTENANCE

OIL LUBRICATED THRUST POT (SEE PAGE 19)

⚠ WARNING *Pumps are shipped without oil. Oil-lubricated bearings must be lubricated at jobsite.*

It is a good practice to flush the oil reservoir before first time operation and at the time of oil changes to remove all grit particles in the oil reservoir sump. Use the same type of oil to flush reservoir as specified for lubrication. (See page 23 on recommended turbine oil.) Remove drain plug (Item # 37) before flushing. Flushing oil may be poured through oil fill opening (Item #32) after removing oil fill plug. The proper oil level when the unit is not running shall be not more than 1/8” to 1/4” from the top of the oil sight gauge (Item #36). Overfilling may result in overheating of the unit. During operation the oil level in the sight gauge may be higher than the recommended range mentioned above. Under no circumstance is it allowed to rotate the unit when the oil in the sight gauge is not at the required level.

To avoid oxidation of the anti-friction bearings during shut-down periods lasting longer than one week, it is recommended to fill up the oil reservoir until the oil runs over the oil retainer tube (Item #2) and down the shaft so that the bearings remain completely immersed in the oil. Before start-up, do not forget to drain the excess oil to its required level. Oil change depends on the severity of the environment. Generally speaking, when the oil in the sight gauge changes to a darkish brown color it is time for an oil change. However, for a longer bearing life, it is recommended that the oil be changed every six months. Be sure to flush the oil reservoir (see above) with each oil change.

GREASE LUBRICATED THRUST POT (SEE FIGURE 13)

Lubricating Intervals in Operating Hours

Thrust Rating	Operating Speed (RPM)			
	<1770	1770	2900	3500
2000 lbs	2000	2000	2000	1800
4000 lbs	2000	2000	1600	1400
6600 lbs	2000	2000	1400	1200

The bearing is pre-lubricated at factory. Re-grease the bearing according to the following procedure and per the schedule in the above table.

- Wipe dirt from grease fittings.
- Check relief port 180° from fitting to make sure it is open.
- Fill the grease cavity through the fitting until fresh grease comes out the relief hole.

- Ensure the relief port closes.

NOTE: The bearing temperature usually rises after re-greasing due to an excess supply of grease. Temperature will return to normal after the pump has run and purged the excess from the bearings, usually two to four hours.

For most operating conditions, lithium based NLGI 2 grease is recommended. This is the grease factory used for pre-lubrication. This grease is acceptable for bearing temperatures of 5° to 230° F. Temperature extremes (either high or low) may require different type grease. Following table lists some various manufacturers’ compatible grease:

Mobil	Mobilith AW2
Amoco	Amolith EP2
Ashland	Multilube EP2
Exxon	Unirex N2
Shell	Alvania EP LF2
Unocal	Unoba EP2
Chevron	Dura-Lith EP NLGI2

NOTE: If it is necessary to change the grease type or consistency, the bearing must be removed and all the old grease eliminated from the housing and bearing.

⚠ WARNING *Bearings must be lubricated properly in order to prevent excess heat generation, spark and premature failure.*

SEASONAL SHUTDOWN

⚠ WARNING *Prior to restating the pump, manually rotate the shaft several times.*

- For oil lubricated pumps that are shut down for an extended period of time, it is suggested that the pump be operated for at least 15 minutes every two weeks with oil feed wide open 2 hours before and during startup in order to maintain a film of oil on the shafting and shaft bearings.
- For product (or water) lubricated pump, if the pump is to be shut down for an extended period of time, operate it for at least 15 minutes with adequate pre-lubrication every two weeks.
- Before resuming normal operations, oil should be changed on drivers, right angle gear and lubricating oil system. After 15 minutes of operation, readjust the lateral.

RECOMMENDED LUBRICANTS

	Grease for Suction Bowl Bearings and Shaft Packings	Turbine Oil for Thrust Pot
Operating Temperature Range	20° F to 120° F	20° F to 120° F
Required properties Pour Point : Flash Point : 100° F Viscosity : ASTM Dropping Point : Nitrile Rubber Swell : Thickener Type: Thickener Percent:	20° F or lower (base oil) 300° F or higher (base oil) 450 SUS or higher (base oil) 160° F or higher Minimal (up to 3%) Calcium or Lithium 15% Minimum	20° F or lower 300° F or higher 150 SUS or higher 32 Minimal (up to 3%)

Manufacturer	Recommended Standard Industrial Lubricants	
Chevron Texaco Corp.	Chevron	Chevron
	Ulti-Plex Grease EP2	*Hydraulic Oil AW32
	Texaco	Texaco
	Novatex EP2	*Regal EP 32
CITGO Petroleum Corp.	Mystik Oil & Grease	Mystik Oil & Grease
	Mystik JT-6 Grease (5484)	*Mystik Turbax Oil 32 (1812)
	Citgo Oil & Grease	Citgo Oil & Grease
	Premium Lithium EP2	Pacemaker Oil 32
	Lyondell Lubricants	Lyondell Lubricants
	Litholine HEP Grease	*Duro Oil 32
Exxon Mobil Corp.	Mobil	Mobil
	Mobilux Grease EP2	DTE Oil 24
	Exxon	Exxon
	Lodok EP 2	*Nuto H Hydraulic Oil 32
76 Lubricants Co.	76 Lubricants	76 Lubricants
	Multiplex EP Grease 2	Hydraulic Oil AW/D 32
Shell Oil	Shell	Shell
	Alvania EP Grease 2	*Tellus Plus Oil 32

Note: * in front of the oil grade means it is suitable for sub zero (F) temperature service.

Manufacturer	Recommended Food Machinery Lubricants	
Chevron Texaco Corp.	Chevron	Chevron
	#FM Grease EP2	*#Lubricating Oil FM32
	Texaco	Texaco
	#Cygnus Grease 2	#Cygnus Hydraulic Oil 32
CITGO Petroleum Corp.	Mystik Oil & Grease	Mystik Oil & Grease
	#Mystik FG2 Grease (5607)	#Mystik FG/AW 32 Oil (1931)
	Citgo Oil & Grease	Citgo Oil & Grease
	#Clarion FG HTEP Grease	#Clarion FG AW Oil 32
	Lyondell Lubricants	Lyondell Lubricants
	Ideal FG 2 Grease	#Ideal FG 32 Oil
Exxon Mobil Corp.	Mobil	Mobil
	#Mobil Grease FM102	DTE FM 32 Oil
	Exxon	Exxon
	Foodrex FG 1	*Nuto FG Hydraulic Oil 32
76 Lubricants Co.	76 Lubricants	76 Lubricants
	76 Pure FM Grease	76 FM Oil 32

Note: 1. * in front of the oil grade means it is suitable for sub zero temperature (F) service.

2. Food machinery lubricants meet USDA H-1 requirements and FDA document 21 CFR 178.3570.

In addition, # in front of the product name means it is NSF 61 registered products.

TROUBLESHOOTING		
TROUBLE	PROBABLE CAUSE	REMEDY
1. Pump does not start	A. Electrical circuit open or not completed B. Improper lateral adjustment. Impeller on bottom. C. Low voltage supplied to electric driver D. Defective motor	Check circuit and correct. Reset impeller adjustment, See pages 15 or 16. Check whether driver wiring is correct and receiving full voltage. Consult factory.
2. No liquid delivered	A. Discharge valve closed B. Speed is too low C. Damaged bowl assembly; Broken or disconnected shaft D. Driver with reduced voltage, or Reduced current starting does not come up to speed E. Barrel/Discharge head not properly vented. F. Suction valve closed.	Be sure the discharge valve is in full open position. Check if driver is directly across the line and receiving full voltage. Pull pump and repair all damaged components. Check RPM, voltage, and amps. Open vent. Confirm valve position.
3. Not enough liquid	A. Same as items 2-A thru 2-E B. Cavitation C. Impellers adjusted too high D. Air or gas in the water E. Excessive pump wear F. Suction valve partially open	Same as items 2-A thru 2-E. Insufficient NPSH available. Consider lowering the bowl assembly by adding column. See pages 15 or 16. If successive starts and stops do not remedy, lower pump if possible, or close discharge valve to maintain well pumping level at a lower GPM. Pull pump and repair as required. Confirm valve position.
4. Not enough pressure	See (3.) Not enough liquid.	See (3.) Not enough liquid.
5. Pump works for a while and quits	A. Excessive horsepower required. B. Pumping higher viscosity or specific gravity liquid than designed for. C. Mechanical failure of critical parts D. Suction strainer clogged E. Misalignment F. Same as 2E, 2F and 3F	Use larger driver. Consult factory. Test liquid for viscosity and specific gravity. Check bearings and impellers for damage. Any irregularities in these parts will cause a drag on the shaft. Pull pump and clean the strainer. Realign pump and driver. Same as 2E, 2F and 3F

TROUBLESHOOTING

TROUBLE	PROBABLE CAUSE	REMEDY
6. Pump takes too much power	A. Damaged impeller B. Foreign object lodged between impeller and bowl C. Specific gravity higher than pump designed for D. Viscosity too high, partial freezing of pumpage E. Defective bearing F. Packing is too tight	Inspect, replace if damaged. Remove object as required. Test liquid for viscosity and specific gravity. Check for both. They can cause drag on impeller. Replace bearing, check shaft or shaft sleeve for scoring. Release gland pressure. Retighten. (See page 21.) Keep leakage flowing. If no leakage, check packing, sleeve or shaft.
7. Pump is too noisy	A. Cavitation B. Bent shaft C. Rotating parts binding, loose or broken. D. Bearings are worn out E. Resonance F. Same as 2F and 3F	Same as Item 3-E. Straighten as required. See Page 10 for runout limits. Replace as required. Replace bearings. Check piping strain, consult factory. Same as 2F and 3F
8. Excessive vibrations	A. Coupling misalignment, bent impeller unbalance, worn bearings, cavitation, piping strain and/or resonance B. Motor or gear driveshaft end play maladjustment C. Bent shaft D. Crooked well. E. Same as 2F and 3F	Determine cause utilizing shaft vibration frequency analyzer and/or disassemble pump. Complex problem may require factory service assistance. See Installation of Hollow Shaft Driver (VHS), Page 14. Straighten as required. See Page 10 for runout limits. Survey the well and consult factory. Same as 2F and 3F
9. Pump leaks excessively at stuffing box	A. Defective packing B. Wrong type of packing	Replace worn packing. Replace packing not properly installed or run-in. Replace improper packing with correct grade for liquid being pumped.
10. Stuffing box is overheating	A. Packing is too tight B. Packing is not lubricated C. Wrong grade of packing D. Stuffing box improperly packed	See item 6-F. Release gland pressure and replace all packing if burnt or damaged. Re-grease packing as required. Consult factory. Repack stuffing box.
11. Packing wears too fast	A. Shaft or shaft sleeve worn B. Insufficient or no lubrication C. Improperly packed D. Wrong grade of packing	Pull pump and remachine, or replace shaft and/or sleeve. Repack and make sure packing is loose enough to allow some leakage. Repack properly, make sure all old packing is removed and stuffing box is clean. Consult factory.

Disassembly And Reassembly – SECTION 6

DISASSEMBLY

⚠ WARNING *Before working on pump or motor, lock out driver power to prevent accidental startup and physical injury.*

NOTE: Pump components should be match-marked prior to disassembly to ensure they are reassembled in the correct location.

HEAD AND COLUMN

1. On pumps which are driven through a gear drive, remove the driveshaft between the gear and the prime mover.
2. On pumps, which are electric motor driven, remove the electrical connections at the conduit box and tag the electrical leads, so they can be reassembled the same way they were disassembled.
3. Uncouple driver (or gear box) from pump shaft and mounting flanges and lift off by the lifting lugs or eyebolts as furnished.

⚠ WARNING *Never try to lift entire pump assembly by the lifting lugs or eyebolts furnished for the driver only.*

4. Disconnect discharge head from the discharge piping. Remove all hold down bolts and external piping. Remove coupling, packing box and proceed with disassembly down to the bowls by reversing the procedures described in detail for assembling the unit.

BOWL ASSEMBLY

The bowl assembly is composed of a suction bowl/bell, intermediate bowl(s), top bowl, impellers and securing hardware, bearings, and pump shaft.

Turbine bowl impellers are secured to the shaft by either a taperlock or a key and split thrust ring. Follow only those procedures that apply to the particular construction supplied.

NOTE: Match mark bowl assembly in sequence of disassembly to aid in the reassembly procedure.

TAPERLOCK CONSTRUCTION BOWL DISASSEMBLY

1. Remove capscrews that secure top bowl (669), not shown, to intermediate bowl (670). See Figure 1 or 2.
2. Slide discharge bowl and top bowl off the pump shaft (660).

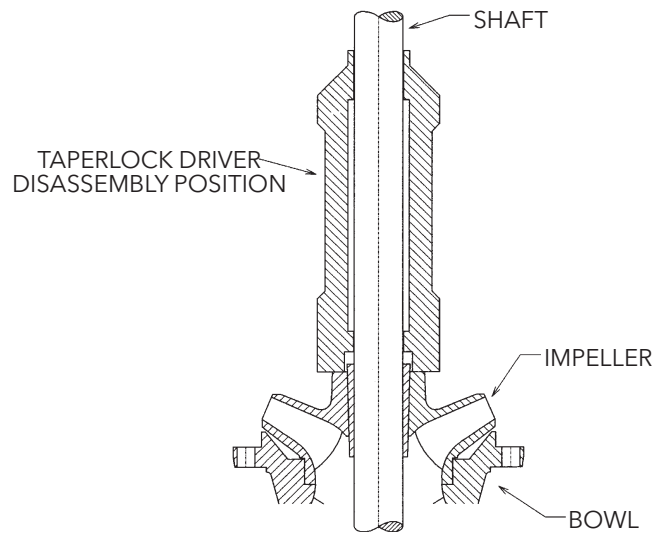

Figure 15

3. Pull shaft out as far as possible and strike impeller hub by using a taperlock driver or equivalent to drive the impeller off the taperlock (See Figure 15).
4. After the impeller is freed, insert a screw-driver into the slot in the taperlock and spread it open. Slide the taperlock and impeller off the pump shaft.
5. Repeat the above procedures until the bowl assembly is completely disassembled.

KEYED BOWL DISASSEMBLY

1. Remove capscrews that secure top bowl (669) to intermediate bowl (670).
2. Slide top bowl off the pumpshaft (660).
3. Remove capscrews (759) and split thrust ring (725) from pump shaft.
4. Slide impeller off the pumpshaft and remove the key (730). If impeller is seized to the shaft, strike impeller with a fiber mallet and drive impeller off the pumpshaft.
5. Repeat the above procedures until the bowl assembly is completely disassembled.

TURBINE BOWL – WEAR RING REMOVAL

1. Remove set screws or grind off tack weld, when rings are furnished with those locking methods.
2. Utilizing a diamond point chisel, cut two “V” shaped grooves on the bowl wear ring approximately 180° apart. Use extreme care not to damage the wear ring seat.
3. With a chisel or drift, knock the end of one half of the ring in, and pry the ring out.
4. On special materials such as chrome steel, set up the bowl in a lathe and machine the wear ring off using extreme care not to machine or damage the ring seat.

IMPELLER WEAR RING REMOVAL

1. Utilizing a diamond point chisel, cut two "V" shaped grooves on the impeller wear ring approximately 180 degrees apart. Use extreme care not to damage the wear ring seat.
2. With a chisel or drift, knock the end of one half of the ring out, and pry the ring off.
3. On special materials such as chrome steel, set up the impeller in a lathe and machine the wear ring off using extreme care not to machine or damage the ring seat.

BOWL AND LINESHAFT BEARING REMOVAL

Utilizing an arbor press and a piece of pipe or sleeve with outside diameter slightly smaller than the outside diameter of the bearing to press the bearing out.

NOTE: Bowl bearings are press fit. Do not remove unless replacement is necessary.

INSPECTION AND REASSEMBLY

INSPECTION AND REPLACEMENT

1. Clean all pump parts thoroughly with a suitable cleaner.
2. Check bearing retainers for deformation and wear.
3. Check shafts for straightness and excessive wear on bearing surfaces. Average total run-out should be less than 0.0005" TIR per foot, not to exceed 0.005" T.I.R. for every 10 feet of shafting.
4. Visually check impellers and bowls for cracks and pitting. Check all bowl bearings for excessive wear and corrosion.
5. Replace all badly worn or damaged parts with new parts. In addition, replace all gaskets and packing as required.

TURBINE BOWL WEAR RING INSTALLATION

Place chamfered face of the bowl or impeller wear ring towards the ring seat and press the ring into the seat. Use an arbor press or equal, making sure the ring is flush with the edge or the wear ring seat.

INSTALL BOWL AND LINESHAFT BEARING

(Refer to Figure 1 for components numbers)

1. Press bearing (656) into retainer (652) using an arbor press or equal.
2. Press bearing (690) into suction bowl/bell (689) by using an arbor press or equal. The top of the bearing should protrude above the suction hub equal to the depth of the counter bore in the sand collar.
3. Place the bowl (670) with the flange downward and press bearing (672) through chamfered side of bowl hub until the bearing is flush with the hub by using an arbor press or equal.

REASSEMBLY OF THE BOWL ASSEMBLY WITH TAPERLOCK CONSTRUCTION

1. For ease in re-assembly apply a thin film of turbine oil to all mating and threaded parts.
2. If the sand collar is not assembled to the shaft, install the sand collar. The sand collar is attached to the shaft with a shrink fit. The larger diameter of the counterbore of the sand collar goes toward the suction bell bearing. Heat the sand collar until it slips over the shaft and quickly position it so that the bottom of the sand collar is set according to the "X" dimension, before it cools. See Figure 16. See Table 1 for the "X" dimensions. Slide the plain end of the pump shaft into the suction bowl/bell bearing until the sand collar rests against the suction bowl/bell.

WARNING *Wear protective gloves and use appropriate eye protection to prevent injury when handling hot parts.*

3. Hold the shaft in this position by inserting a long capscrew (or all thread rod with a hex nut) with an assembly jig into the bottom end of the suction hub and secure tight into the threaded hole at the end of the shaft. **Be sure the shaft has been cleaned and checked the straightness.**

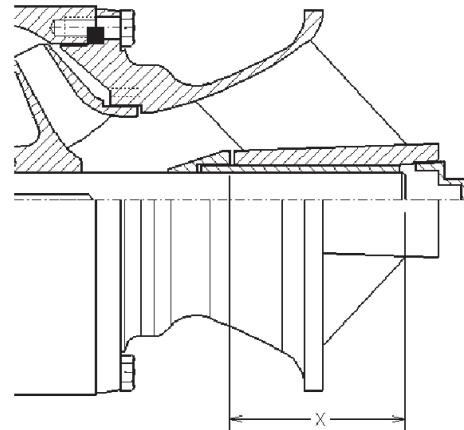

Figure 16

TABLE 1 Sand Collar Location Dimension

Pump Model	"X" Dim.	Pump Model	"X" Dim.
5C, 5T	1.88"	13A, 13RA	7.19"
5WA	1.81"	13C	5.13"
6A, 6RA	3.13"	14DH	8.13"
6C	2.25"	14F, 14H, 14RH	7.13"
6DH	3.50"	14RJ	5.06"
7A, 7RA	3.13"	15F Bowl	9.50"
7C, 7T, 7WA	2.81"	16B	6.56"
8A, 8RA	3.13"	16DH Bowl	8.63"
8DH	4.44"	16DM	5.88"
8RJ	2.88"	16RG	6.69"
9A, 9RA	3.41"	18B	7.25"
9RC, 9T, 9WA	5.19"	18C	6.63"
10A, 10RA	4.31"	18D	7.56"
10DH	6.31"	18GX	5.75"
10L	6.25"	20B, 18L	6.88"
10RJ	5.00"	20E, 18H	7.00"
10WA	5.19"	20C	6.44"
11A, 11RA	5.31"	24C	12.38"
11C	4.88"	24D	9.38"
11WA	5.13"	24E	8.13"
12C	5.31"	24F	10.44"
12FD	5.19"	24G	8.00"
12FR	6.50"	26G	7.75"
12WA, 12RA	5.00"	28G	8.75"
12RJ	4.94"	30B	NA

- Slide the first impeller over the shaft until it seats on the suction bowl/bell.

NOTE: If there are different diameter impellers, put the large diameter impeller at the lower stage.

- Insert a screwdriver into the slot in the taperlock (677) to spread the slot and slide the taperlock over the pump shaft. Hold the impeller against bowl and slide the taperlock into the impeller hub. Be sure the taperlocks have been cleaned and are dry.
- Hold impeller firmly against the suction bowl/bell and drive the taperlock into place with a taperlock driver, (See Figure 17). After the impeller is secured in position, the top end of the taperlock should be 1/8" above the impeller hub.
- Slide intermediate bowl (670) onto shaft and secure with capscrews provided.
- Repeat preceding procedure for number of stages required.
- Remove long capscrew and the assembly jig at the end of suction hub and check that the shaft rotates freely without dragging or binding. Also check for adequate lateral (end play).

FINAL ASSEMBLY

After assembly of bowl assembly, reassemble pump as described in Section 3, Installation. Refer to Section 4, for startup and operation procedures.

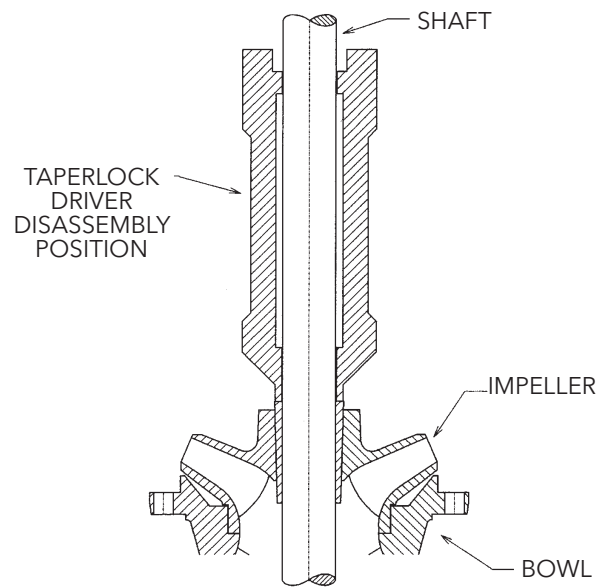

Figure 17

Repair Parts – SECTION 7

ORDERING PARTS

When ordering spare or replacement parts, the pump serial number and size and type of pump must be given. This can be found on the nameplate furnished with the unit. Give the complete name and reference number of each part as indicated on the applicable sectional drawings, Figure 1 or Figure 2, and the quantity required.

STOCKING SPARE PARTS

Spare parts to be kept in inventory will vary according to service, field maintenance, allowable down time and number of units. A minimum inventory of one complete set of bearings and one spare of each moving part is suggested.

RETURNING PARTS

A completed Return Material Authorization (RMA) form must accompany all materials returned to the factory. The RMA forms can be obtained direct from the factory or through your local Goulds Water Technology representative. The RMA form must be filled in completely and forwarded as directed thereon. Parts being returned under warranty claim must have a complete written report submitted with the RMA form.

▲ CAUTION *Returned material must be carefully packaged to prevent transit damage - the factory cannot assume any responsibility for parts damaged in transit.*

LIMITED WARRANTY

Company warrants title to the product(s) and, except as noted with respect to items not of Company's manufacturer, also warrants the product(s) on date of shipment to Purchaser, to be of the kind and quality described herein, and free of defects in workmanship and material. THIS WARRANTY IS EXPRESSLY IN LIEU OF ALL OTHER WARRANTIES, INCLUDING BUT NOT LIMITED TO IMPLIED WARRANTIES OF MERCHANTABILITY AND FITNESS, AND CONSTITUTES THE ONLY WARRANTY OF COMPANY WITH RESPECT TO THE PRODUCT(S).

If within one year from date of initial operation, but not more than 18 months from date of shipment by Company of any item of product(s), Purchaser discovers that such item was not as warranted above and promptly notifies Company in writing thereof, Company shall remedy such nonconformance by, at Company's option, adjustment or repair or replacement of the item and any affected part of the product(s). Purchaser shall assume all responsibility and expense for removal, reinstallation, and freight in connection with the foregoing remedies. The same obligations and conditions shall extend to replacement parts furnished by Company hereunder. Company shall have the right of disposal of parts replaced by it. Purchaser agrees to notify Company, in writing, of any apparent defects in design, material or workmanship, prior to performing any corrective action back-chargeable to the Company. Purchaser shall provide a detailed estimate for approval by the Company.

ANY SEPARATE LISTED ITEM OF THE PRODUCT(S) WHICH IS NOT MANUFACTURED BY THE COMPANY IS NOT WARRANTED BY COMPANY and shall be covered only by the express warranty, if any, of the manufacturer thereof.

THIS STATES THE PURCHASER'S EXCLUSIVE REMEDY AGAINST THE COMPANY AND ITS SUPPLIERS RELATING TO THE PRODUCT(S), WHETHER IN CONTRACT OR IN TORT OR UNDER ANY OTHER LEGAL THEORY, AND WHETHER ARISING OUT OF WARRANTIES, REPRESENTATIONS, INSTRUCTIONS, INSTALLATIONS OR DEFECTS FROM ANY CAUSE. Company and its suppliers shall have no obligation as to any products which have been improperly stored or handled, or which have not been operated or maintained according to instructions in Company or supplier furnished manuals.

LIMITATION OF LIABILITY - Neither Company nor its suppliers shall be liable, whether in contract or in tort or under any other legal theory, for loss of use, revenue or profit, or cost of capital or of consequential damages, or for any other loss or cost of similar type or for claims by Purchaser for damages of Purchaser's customers. Likewise, Company shall not under any circumstances be liable for the fault, negligence, wrongful acts of Purchaser or Purchaser's employees, or Purchaser other contractors or suppliers.

IN NO EVENT SHALL COMPANY BE LIABLE IN EXCESS OF THE SALES PRICE OF THE PART OR PRODUCT FOUND DEFECTIVE.



Xylem Inc.
PO Box 5487
Lubbock, TX 79408
Phone: 1-806-763-7867
Fax: 1-800-453-4749
www.gouldswatertechnology.com

Goulds is a registered trademark of Goulds Pumps, Inc. and is used under license.
© 2017 Xylem Inc. IOMGWICR01-EN August 2017