

SUBMERSIBLE SLURRY PUMP

Series: KMUD

Model: 6KMUD1503 / 1504

15 HP / 1750 RPM

Discharge: 6"



► Built-in high chrome alloy agitator.

DISCHARGE

6" vertical for hose coupling. Cast iron ASTM A-48 class 30.

LIQUID TEMPERATURE

104°F (40°C)

UPPER COVER

Cast iron ASTM A-48 class 30.

PUMP BODY

Cast iron ASTM A-48 class 30.

MOTOR HOUSING

Cast iron ASTM A-48 class 30.

IMPELLER

Design: semi-open.

Material: high chrome alloy.

AGITATOR

High chrome alloy.

INLET PLATES

Cast iron & high chrome alloy.

SHAFT

420 AISI stainless steel.

HARDWARE

304 series stainless steel.

O-RINGS

Nitrile rubber (NBR).

PAINT

Air dry enamel, water based.

SEAL

Design: double mechanical, oil filled chamber.

Material: TC-SiC / SiC-SiC. Stainless steel hardware.

CORD ENTRY

50 ft of neoprene cord, sealed against moisture.

MOTOR

Three phase induction motor, 230 & 460 volts, 60 Hz, 1750 RPM. Insulation class F and IP68 protection class.

STRAINER

Steel.

HANDLE

Steel.

ACCESSORIES

Includes a discharge adapter for NPT threads.

*TC: Tungsten Carbide, SiC: Silicon Carbide

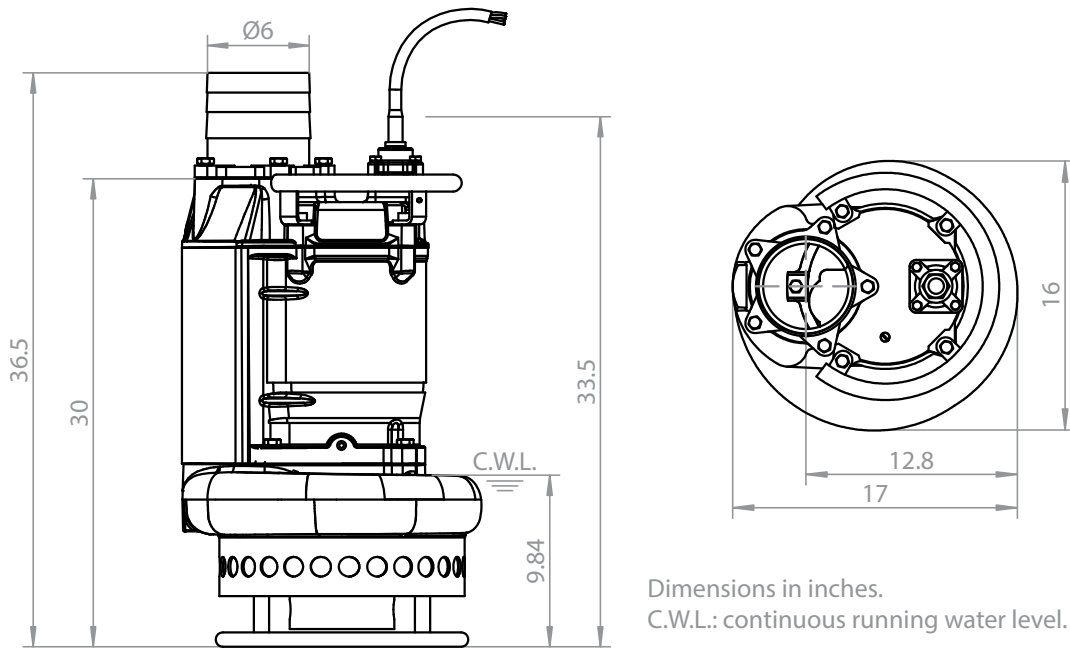

Dimensions in inches.
C.W.L.: continuous running water level.

MODEL	PART No.	DISCHARGE	HP	VOLTS	PHASE	RPM (Nominal)	MAX AMPS	WEIGHT (pounds)
6KMUD1503	70090281	6"	15	230	3	1750	36.4	434
6KMUD1504	70090282	6"	15	460	3	1750	18.2	434

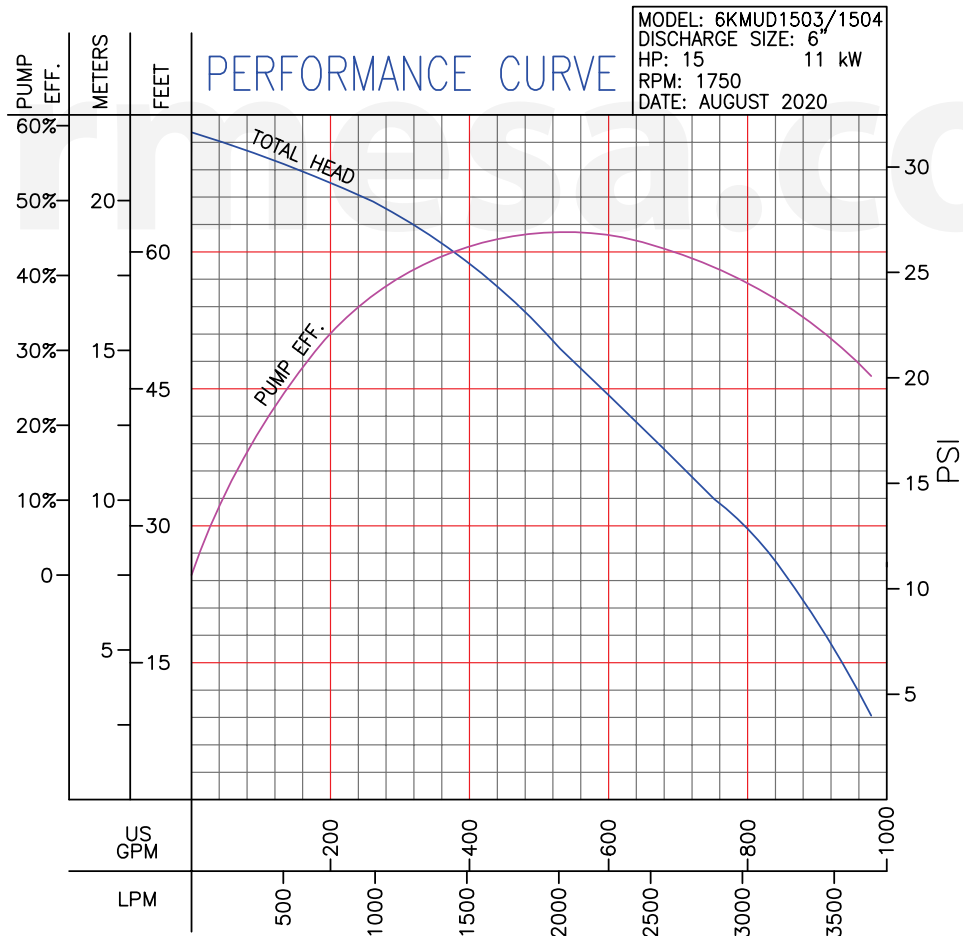

IMPORTANT!

1. Never use this pump to handle explosive liquids.
2. This pump is not approved to be used in swimming pools, recreational installations or any application where human contact may be common.
3. Testing is performed with water specific gravity of 1.0 @ 68 °F (20 °C); other fluids may vary performance.